

# XPS, Optical properties

**Peter Blaha**

Institute of Materials Chemistry, TU Wien

**(Xavier Rocquefelte)**

University of Rennes

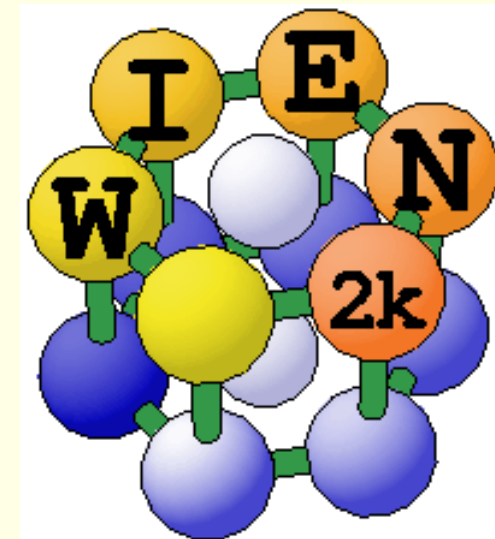



# Photoemission spectroscopy, PES



- Illuminate sample with light of known energy, measure kinetic E of emitted electrons  $e^-$

→ core- $e^-$ , Valence-DOS

## ■ Energyconservation:

$$\hbar\omega = \phi + E_{kin} + E_b$$

- $\phi$ : work function
- $E_{kin}$ : kinetic E of  $e^-$
- $E_b$ : bindingenergy of  $e^-$

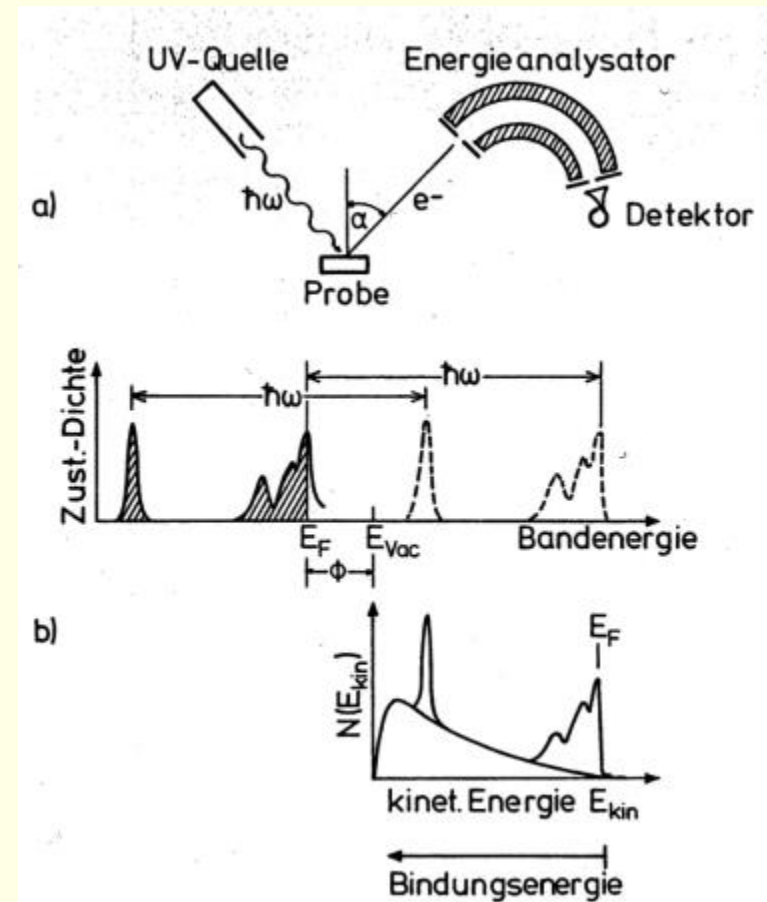

- UPS: UV (He-light, 21.1 und 40.4 eV), for valence-electrons
- XPS, ESCA: X-rays (Al 1486 eV), for core and valence-electrons
- Synchrotronradiation: UV or X-rays of "any" wavelength

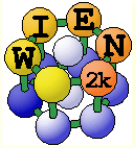

# Work function



Work-  
function

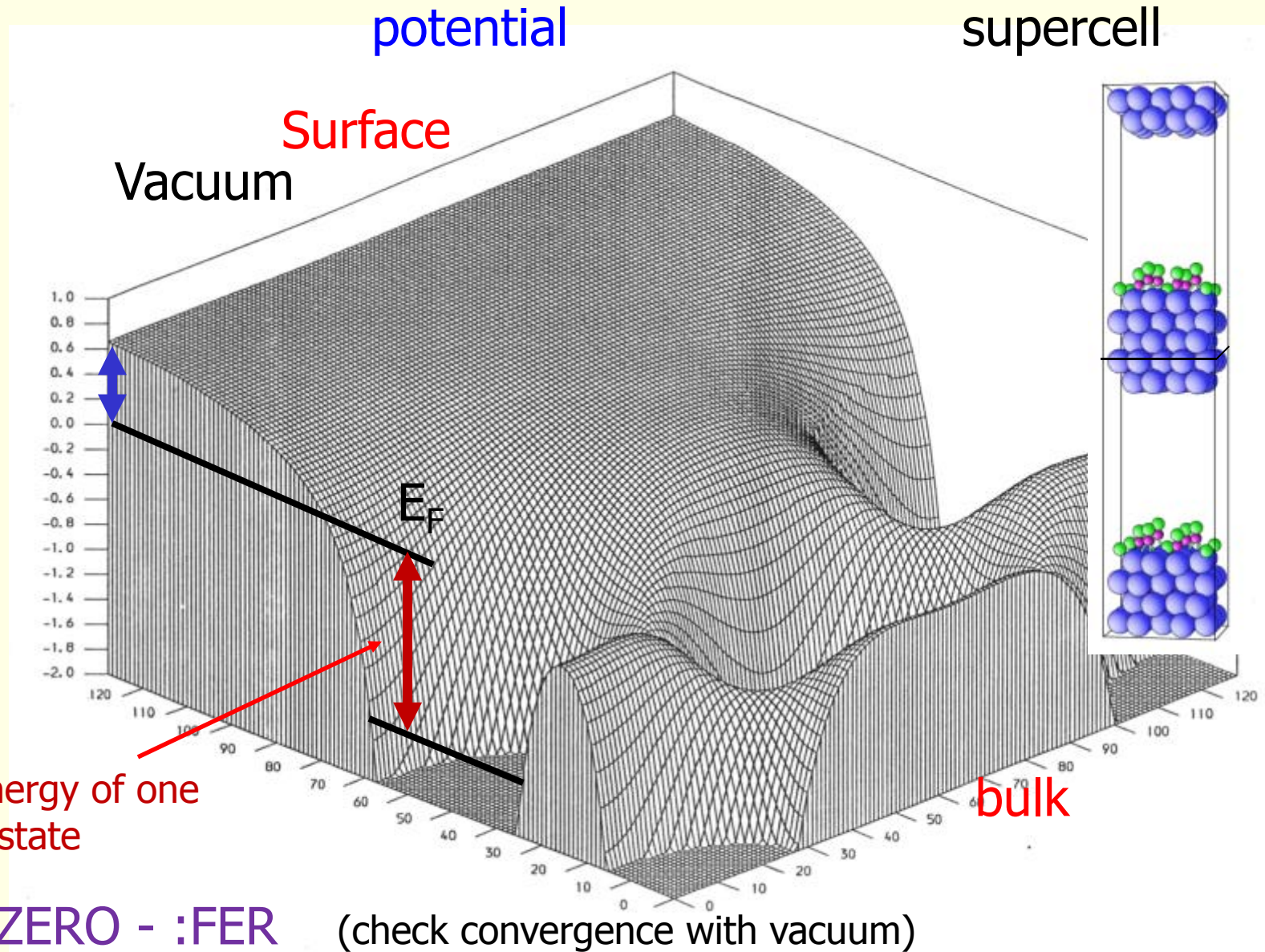



# XPS, core-level shifts



- Ionization potential of core- $e^-$ ,  $IP = E^{\text{tot}}(N) - E^{\text{tot}}(N-1)$ 
  - *gives information on charge state of the atom*
- core-eigenvalues  $\varepsilon_i$  are NOT a good approximation:  $\varepsilon_i = dE/dn$
- **Slater's "transition state"**: core-eigenvalues  $\varepsilon_i$  for half occupancy

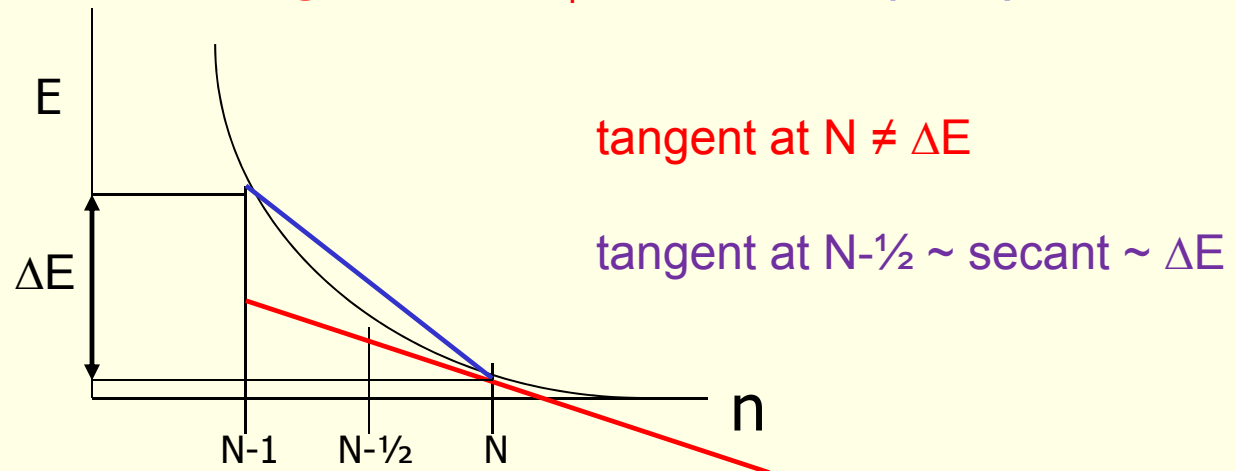

- $\Delta$ -SCF-calculation with and without core-hole:  $E^{\text{tot}}(N) - E^{\text{tot}}(N-1)$ 
  - *supercells to reduce hole-hole interaction*

C,N 1s	exp.(eV)	$\varepsilon_i$	$\Delta$ -SCF
TiC	281.5	264.7	281.9
Ti <sub>4</sub> C <sub>4</sub>	281.5	263.3	281.1
TiN	397.0	377.5	397.1

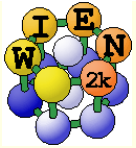

# valence $e^-$ : bandstructure via ARPES



## Normalemission:

Surface state  
d-band  
sp-band



Abb. 3.11a. UP-Spektren einer Cu(111)-Oberfläche bei Detektion normal zur Oberfläche und Variation der Photonenenergie von 6 bis 11,5 eV. Als Energieachse dient die Bindungsenergie bezogen auf die Fermi-Energie, hier als Anfangsenergie der Elektronen bezeichnet [29].

## Brillouinzone fcc:



## Volumenbandstruktur:

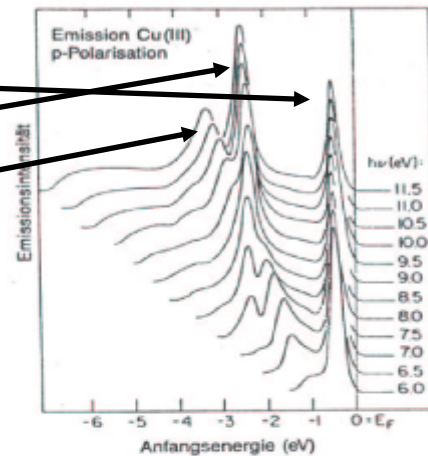
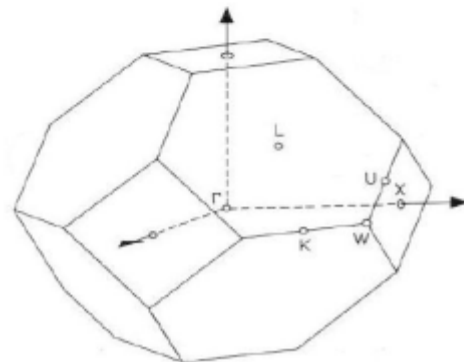

Abb. 3.11b. Aus den Spektren von Abb. 3.11a ermitteltes Bänderschema in den [111]-( $\Gamma$ -L)- und [110]-( $\Gamma$ -X)-Richtungen. Die Punkte geben die gemessenen Peakpositionen aus 3.11a wieder, die Linien sind aus einer theoretischen Bandstruktur. Beim Vergleich mit der Cu-Bandstruktur in der Abb. 3.10 beachte man den unterbrochenen Energiemaßstab und den unterdrückten  $\Gamma$ -Punkt in Abb. 3.11b [29].



# valence PES: usually explained by DOS

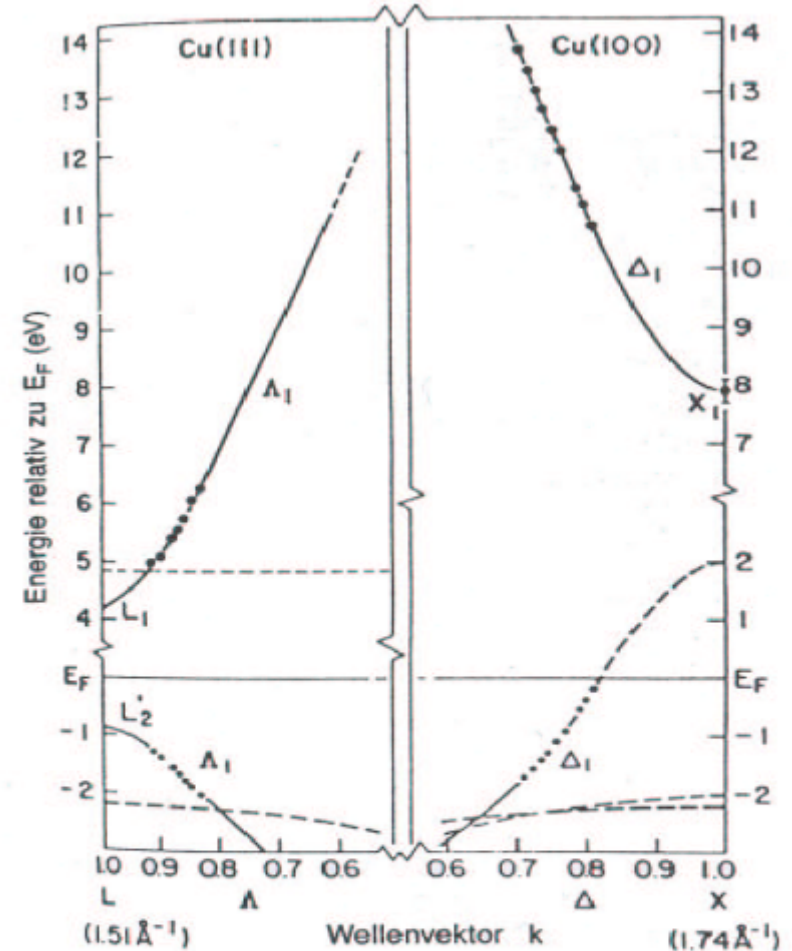

- a single DOS cannot explain the E-dependency of PES

- $I = \sum_{atoms,l} N_{a,l} \sigma_{a,l}$

- $N_{a,l}$  = Partial DOS

- $\sigma_{a,l}$  = atomic cross section

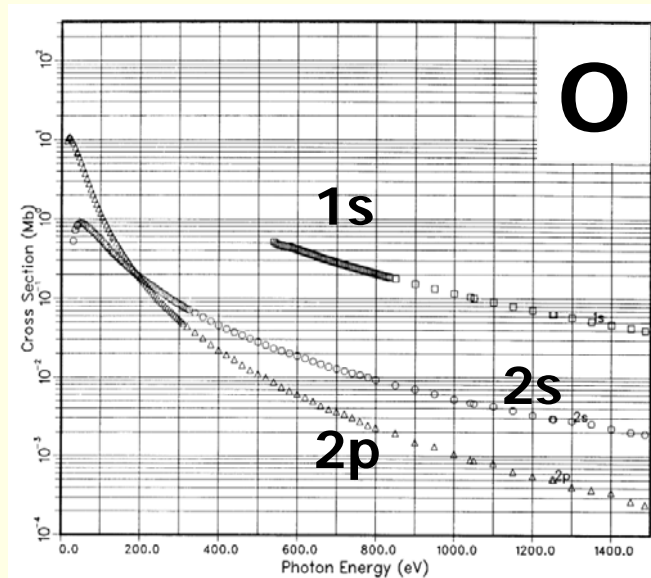

Photoionization cross-sections: a guide to electronic structure

Jennifer C. Green<sup>a,\*</sup>, Piero Decleva<sup>b</sup>

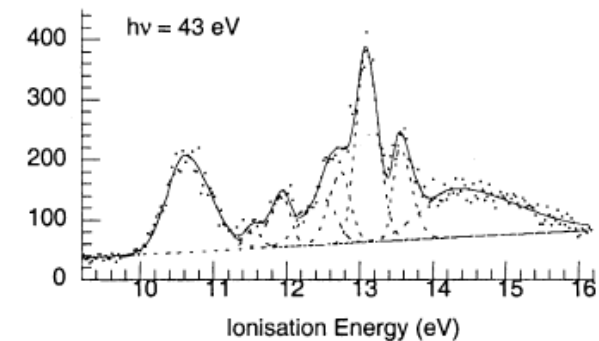
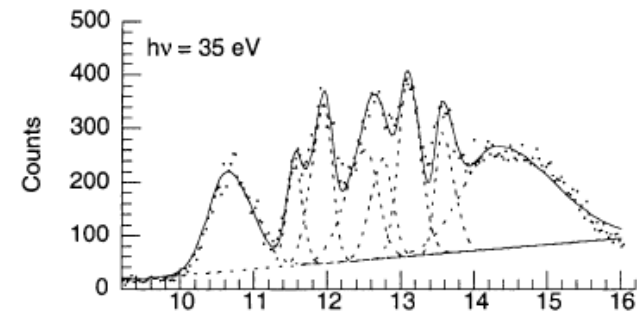
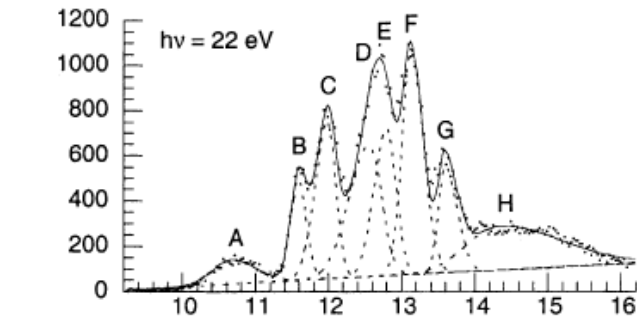

PE spectra of TiMeCl<sub>3</sub> at 22, 35 and 43 eV.

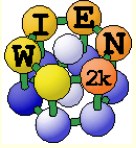

# SiO<sub>2</sub> valence band XPS



- **Total DOS** gives 5 peaks, but wrong intensities
- **Cross section modulated PDOS** gives better intensities
- **Renormalized PDOS \*  $\sigma$**  gives perfect intensities
  - *renormalization according to the inverse charge fraction of an orbital within the atomic sphere + removal of interstitial DOS:*  
$$N_{tot} = \sum_{atoms,l} N_{a,l} + N_{int}$$

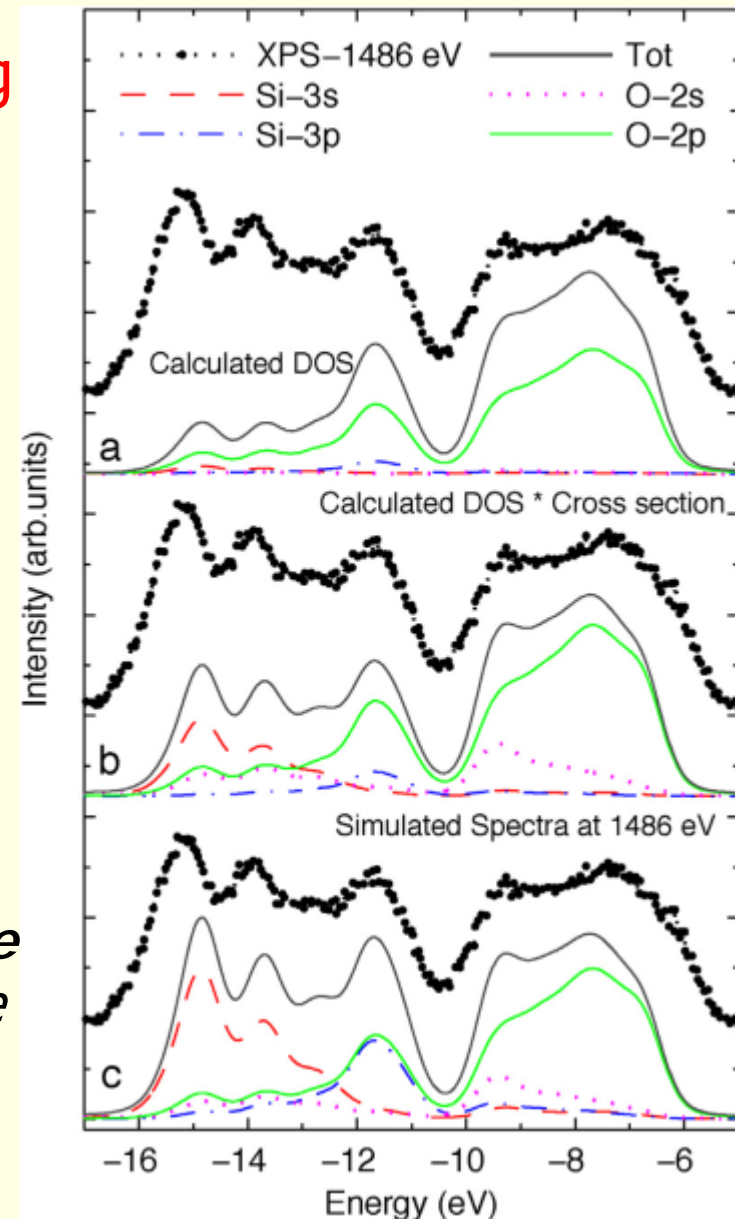

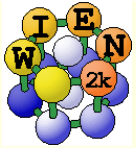

# PbO<sub>2</sub> at 3 different energies

- 56eV: O-2p PDOS explains the spectrum
- 1486 eV: all orbitals contribute
- 7700 eV: O-2p not important

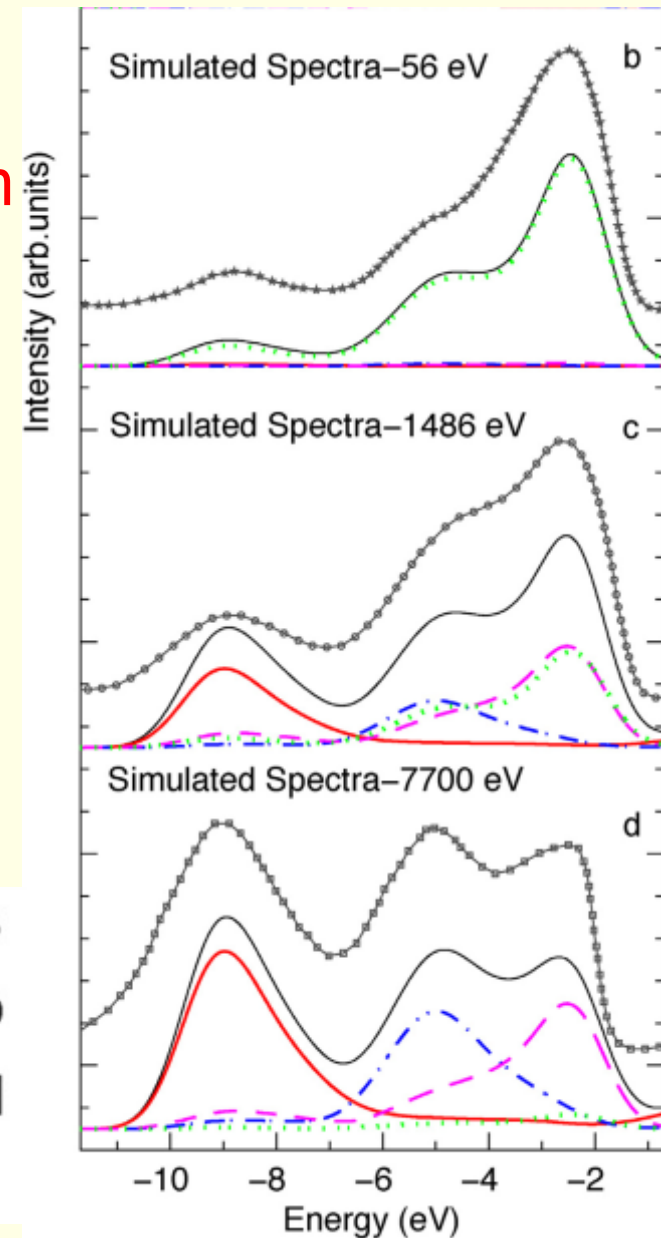
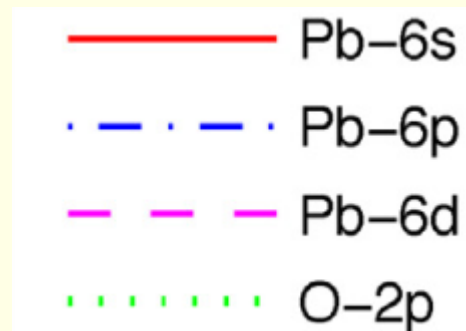



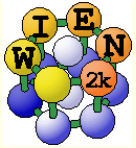

# PBO<sub>2</sub> at very low BE



- 56 eV: almost no intensity till -1 eV
- 7700eV: strong contribution from antibonding Pb-6s

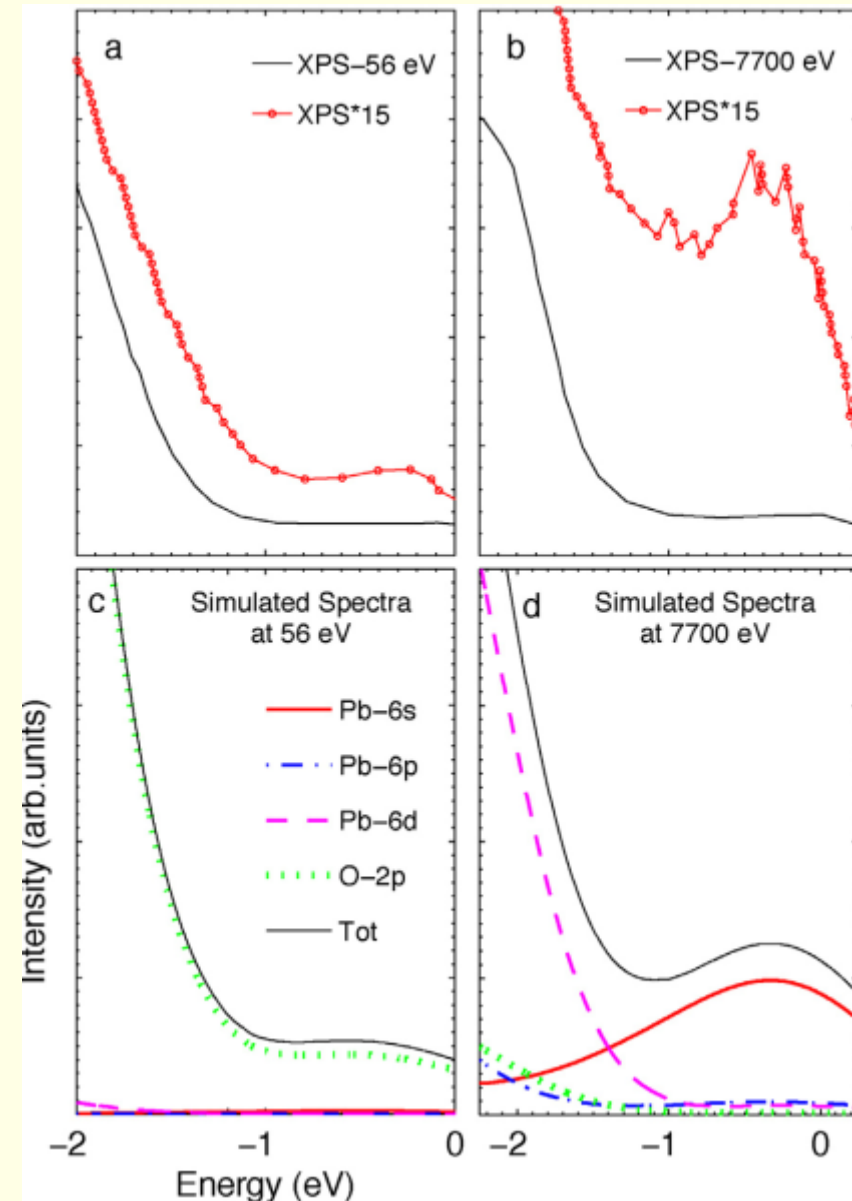

# *Modelling the Optical Properties of Inorganic Materials*

*1 – MULTIPLE FACETS OF COLOURED MATTER*

*2 – ELECTRONIC STRUCTURE OF A SOLID*

*3 – UNDERSTANDING OF COLORS FROM BANDS*

*4 – LIGHT-MATTER INTERACTION*

*5 – OPTICAL PROPERTIES: WHICH TREATMENT?*

*6 – ILLUSTRATIONS*

# 1 – MULTIPLE FACETS OF COLOURED MATTER

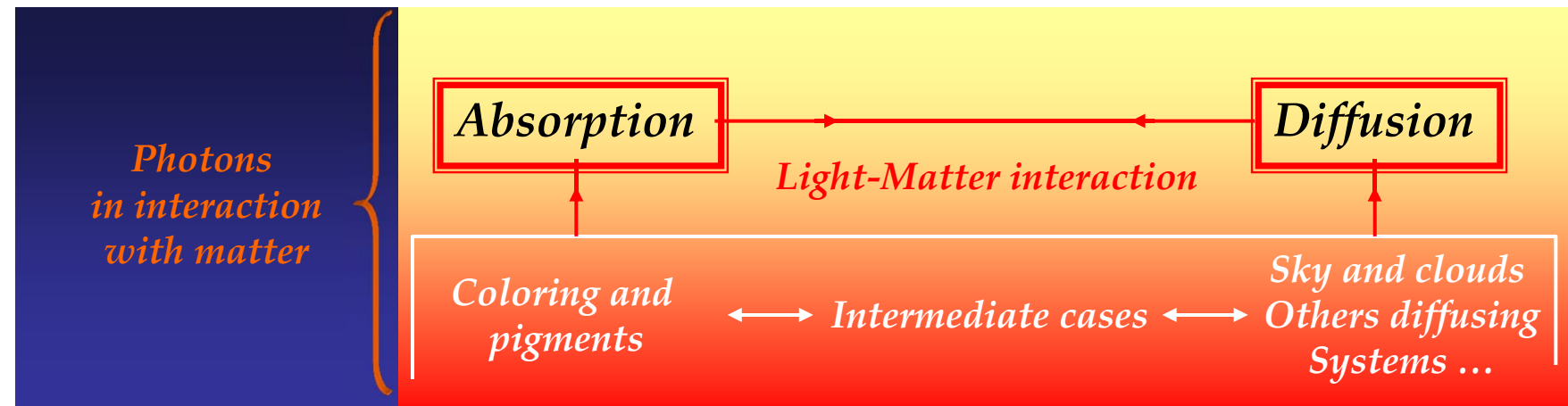

# 1 – MULTIPLE FACETS OF COLOURED MATTER

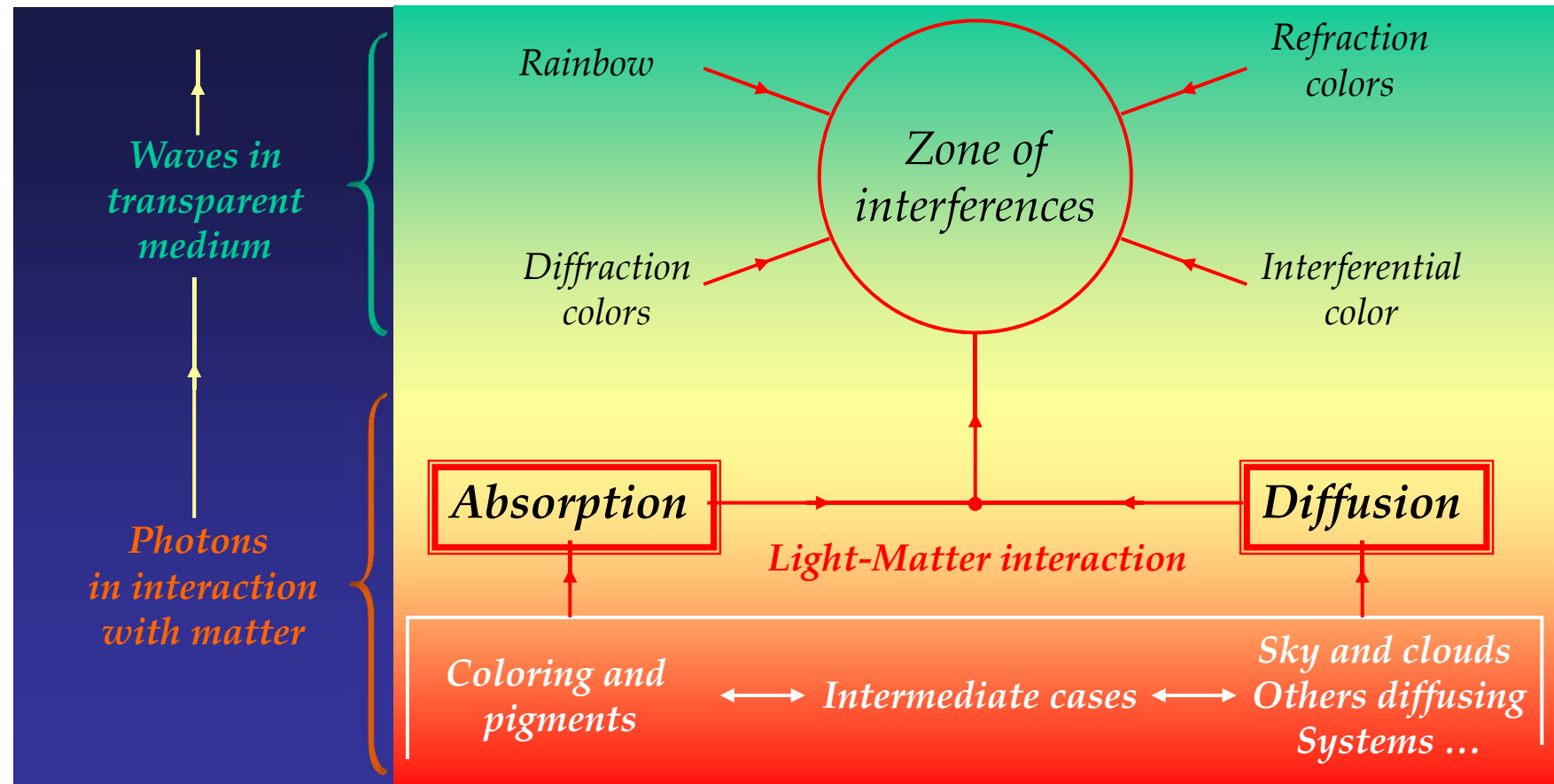

# 1 – MULTIPLE FACETS OF COLOURED MATTER

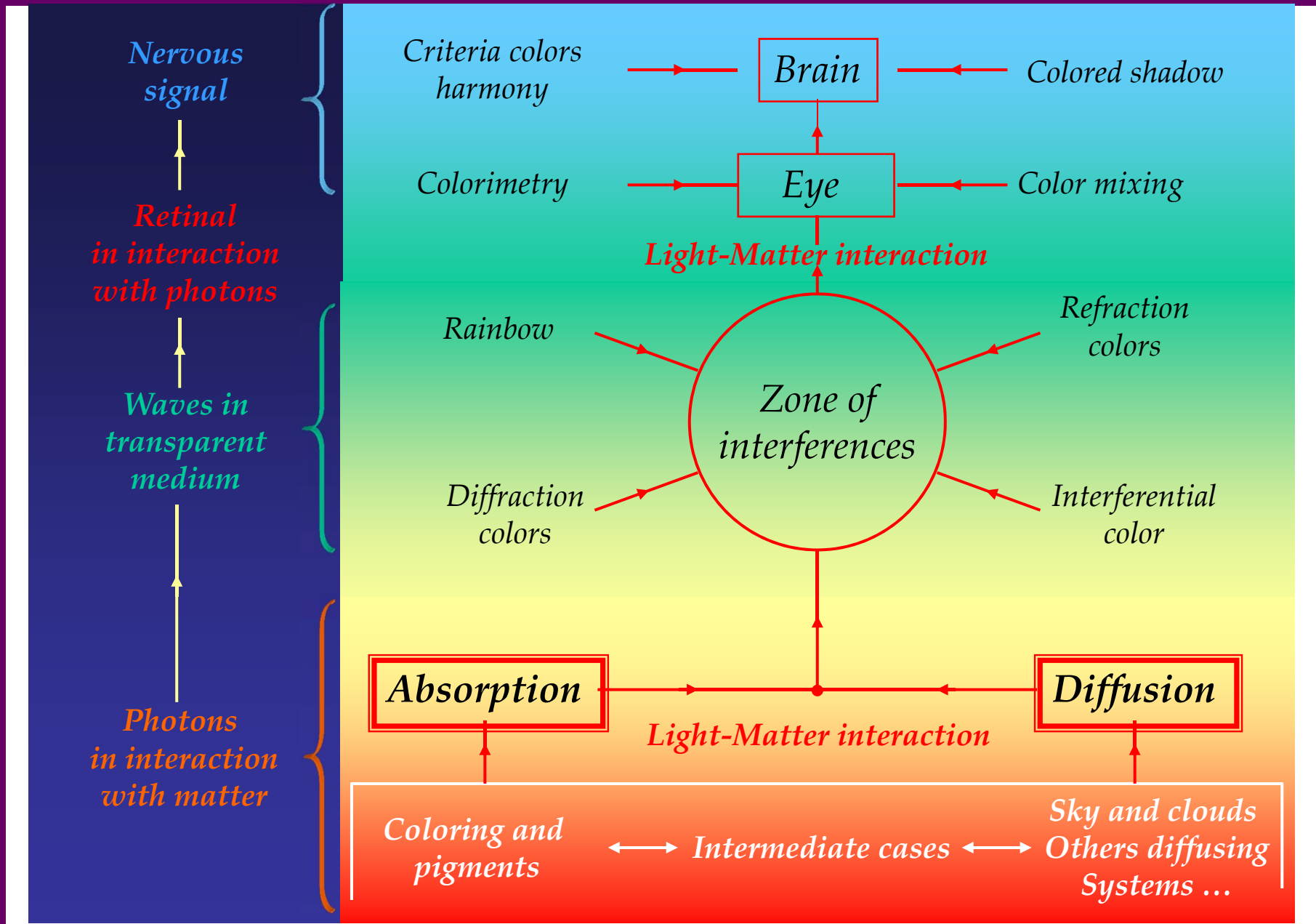

# 1 – MULTIPLE FACETS OF COLOURED MATTER

*Interaction between the electromagnetic field and matter*

*Physical color*



*Diffusion et interferences*

*Dispersion / Reflection et Refraction / Scattering*

*Transparent matter*

# 1 – MULTIPLE FACETS OF COLOURED MATTER

*Interaction between the electromagnetic field and matter*

*Physical color*



*Diffusion et interferences  
Dispersion / Reflection et Refraction / Scattering*

*Transparent matter*

*Chemical color*

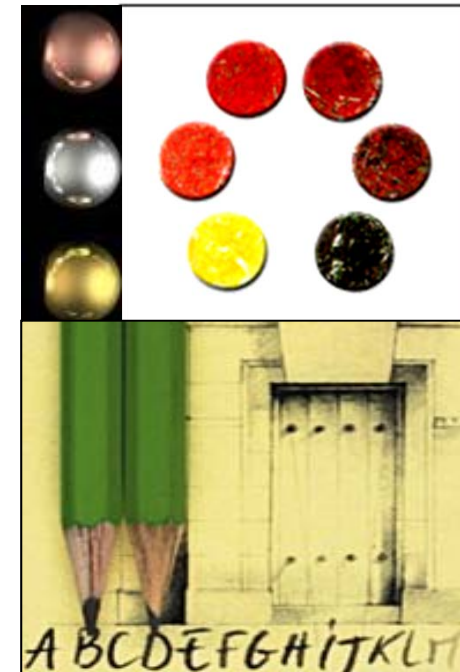

*Absorption  
Energy dissipation*

*Opaque matter*

# 1 – MULTIPLE FACETS OF COLOURED MATTER

*Chemical color → « Inelastic diffusion »*

*Acceptor electron levels ⇒ Dissipative absorption*

*From insulator to semiconductor to metal systems*

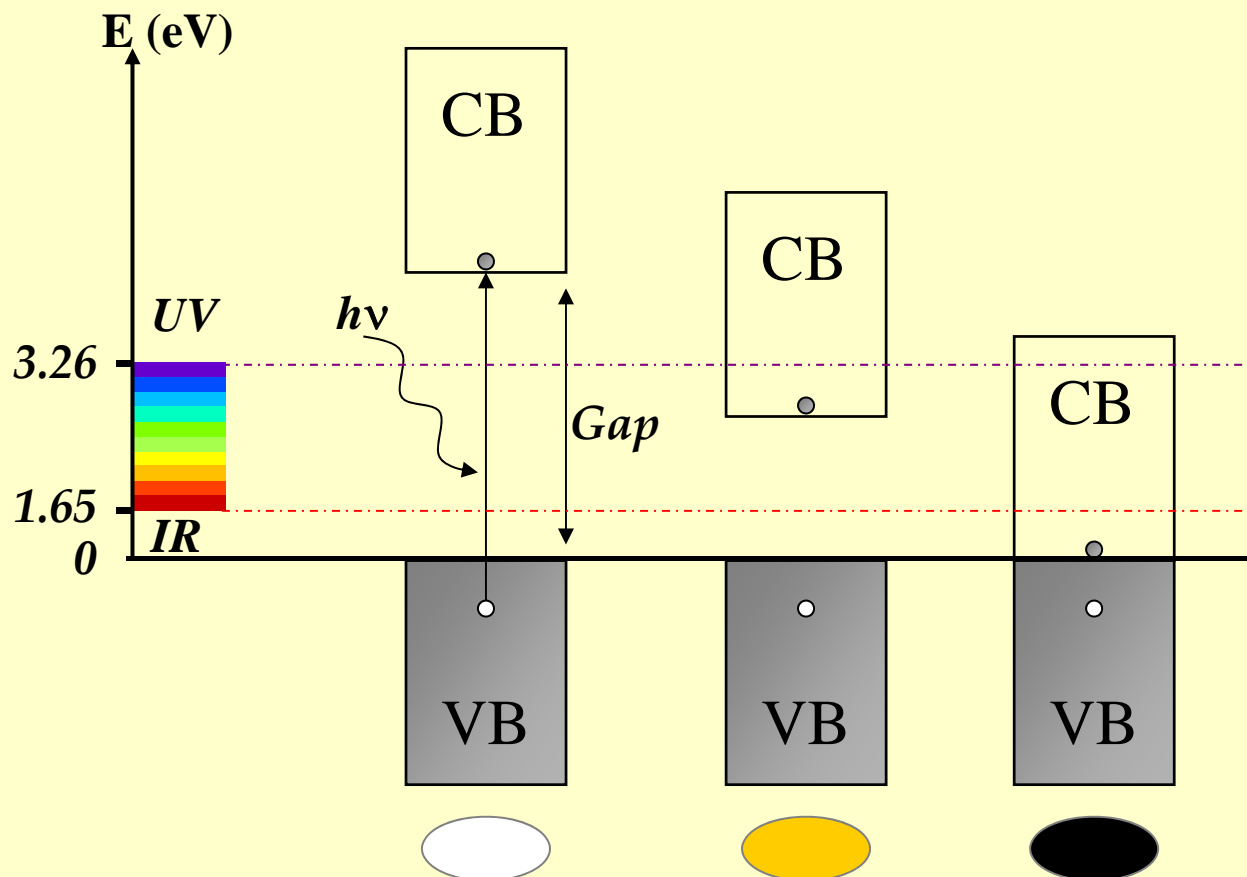

*Chemical colors*

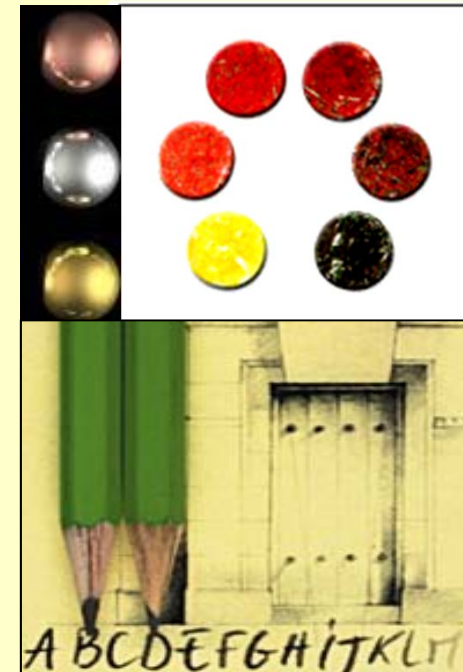

*Absorption  
Energy dissipation  
Opaque Matter*



## 2 – ELECTRONIC STRUCTURE OF A SOLID

From the atom to the molecule and to the solid



## 2 – ELECTRONIC STRUCTURE OF A SOLID

From the atom to the molecule and to the solid

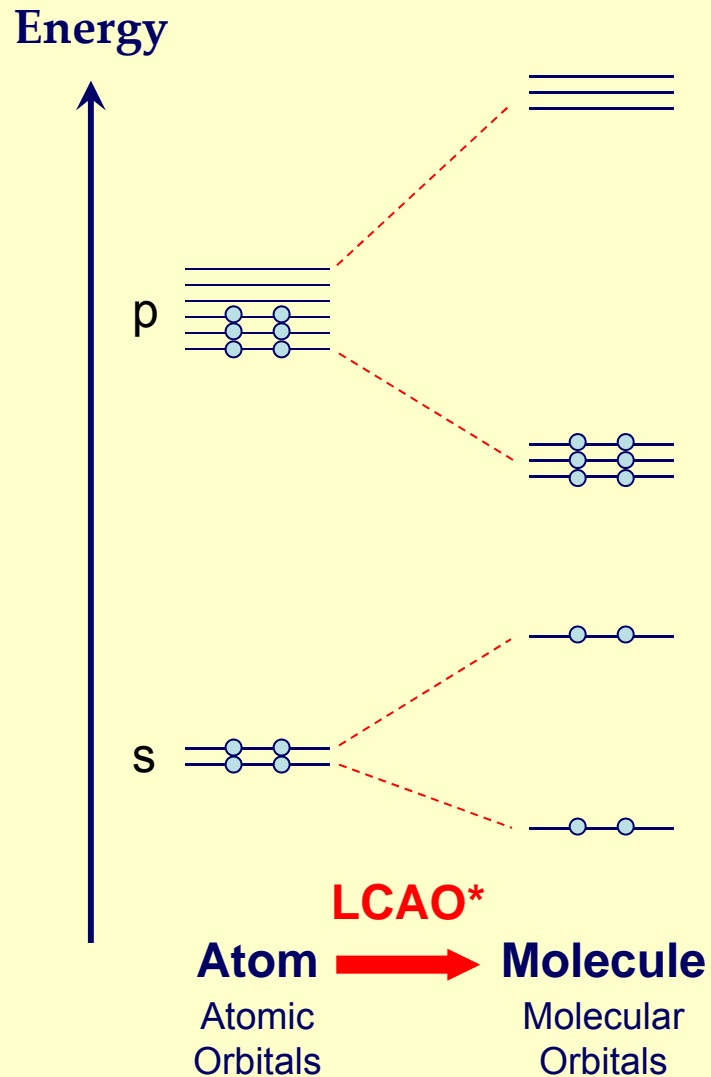

\*LCAO : Linear Combination of Atomic Orbitals

## 2 – ELECTRONIC STRUCTURE OF A SOLID

### From the atom to the molecule and to the solid

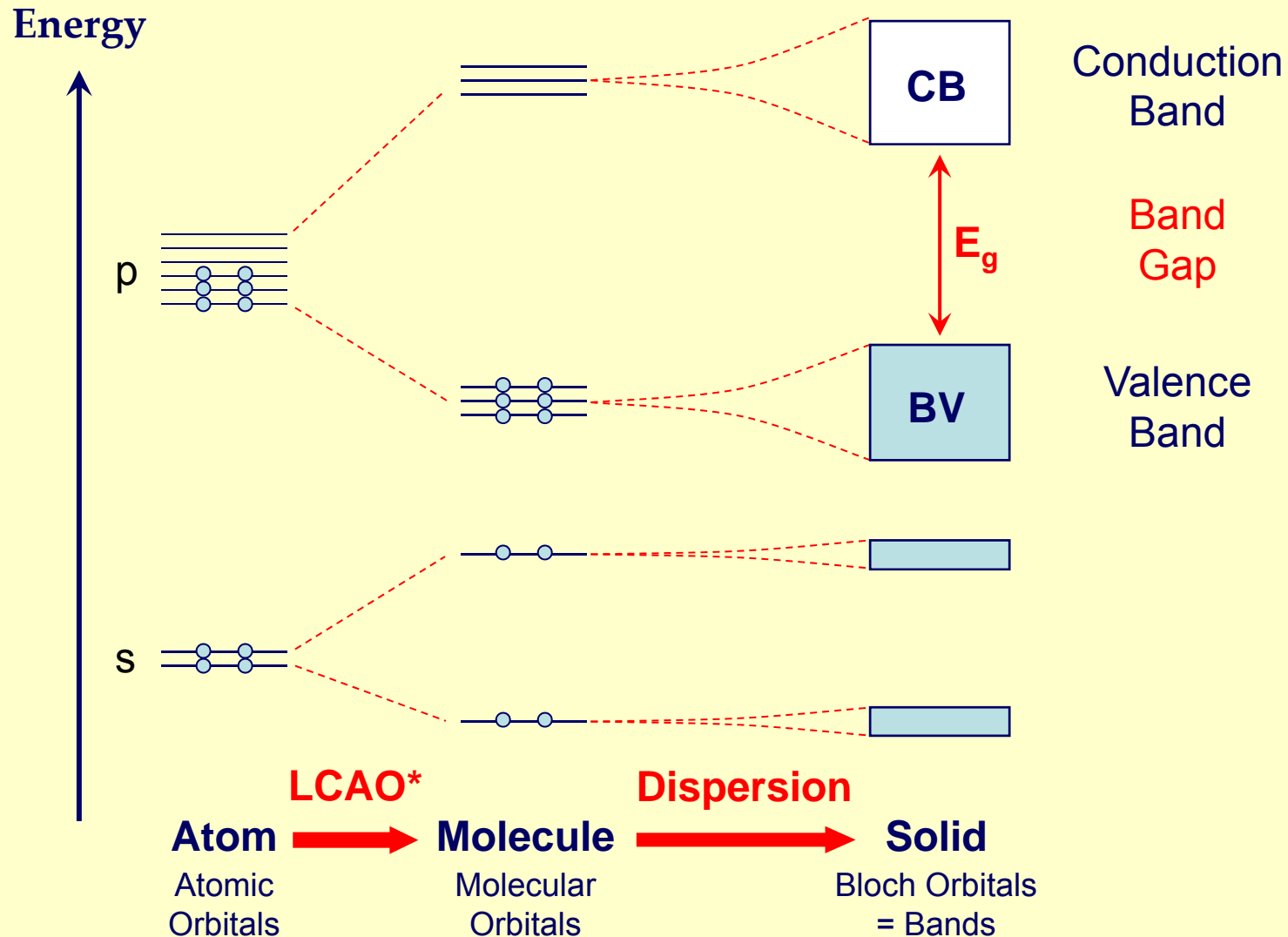

\*LCAO : Linear Combination of Atomic Orbitals

# 3 – UNDERSTANDING OF COLORS FROM BANDS

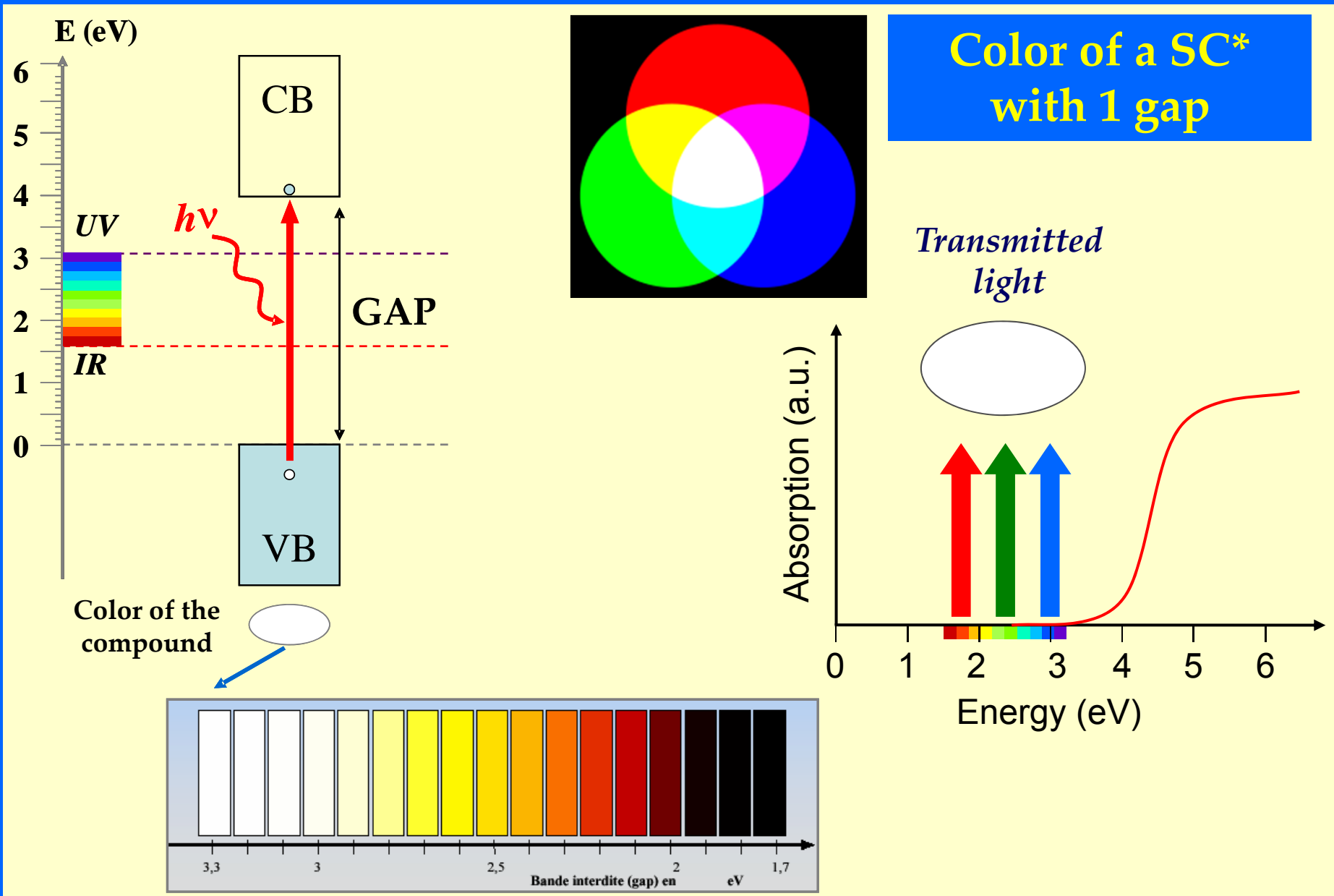

\*SC : Semiconductor

# 3 – UNDERSTANDING OF COLORS FROM BANDS

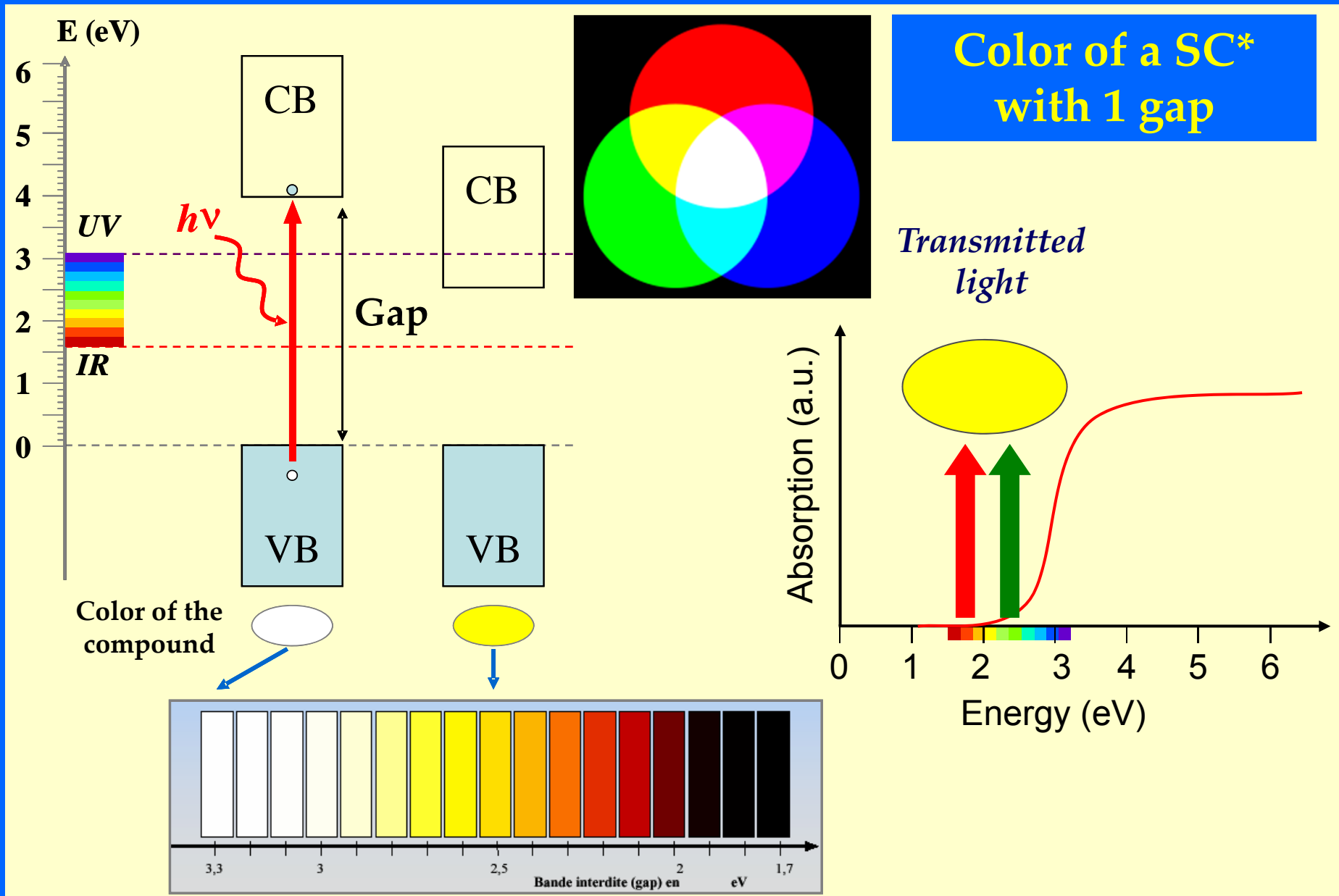

\*SC : Semiconductor

# 3 – UNDERSTANDING OF COLORS FROM BANDS

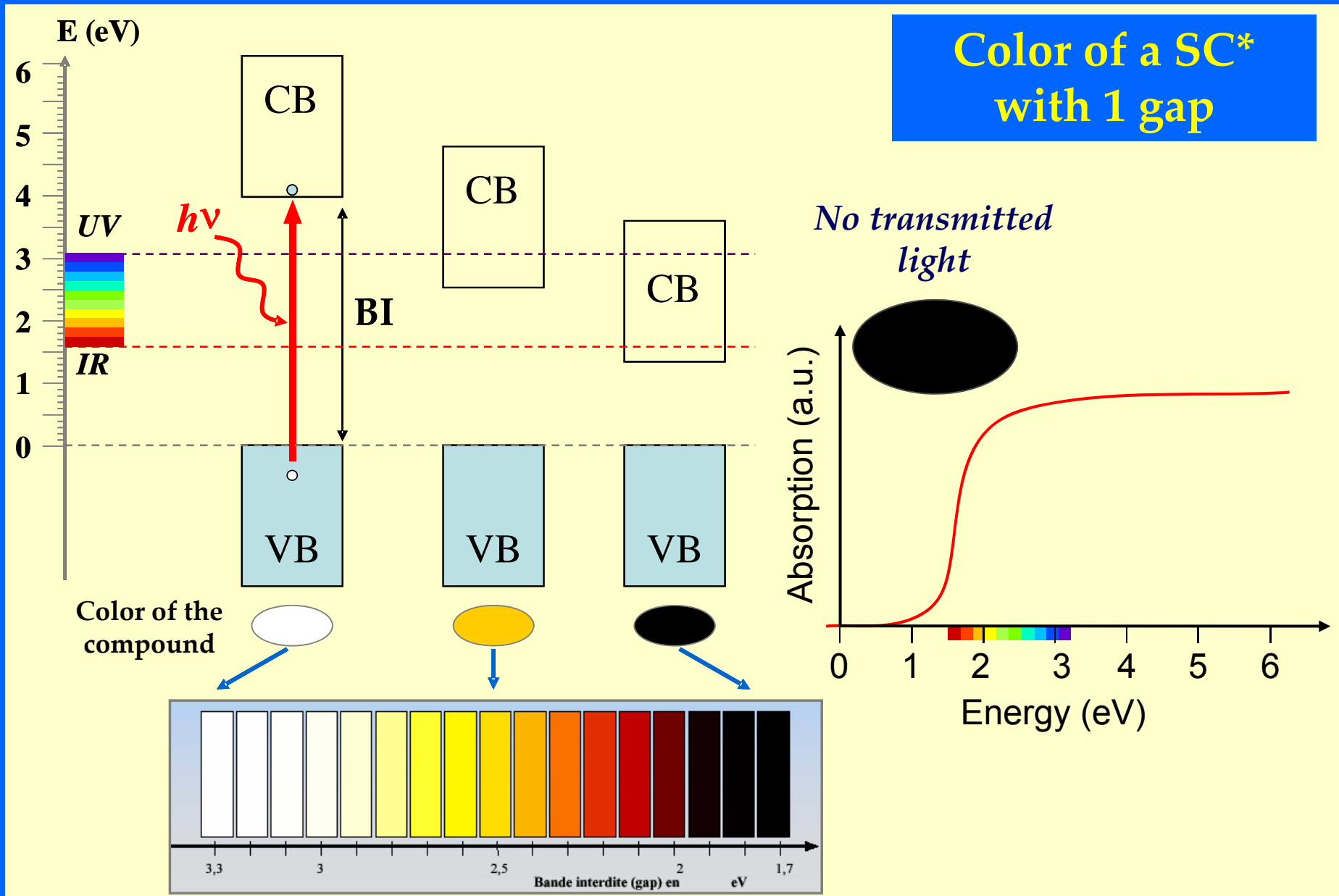

\*SC : Semiconductor

### 3 – UNDERSTANDING OF COLORS FROM BANDS

Color of a SC\*  
with several gaps

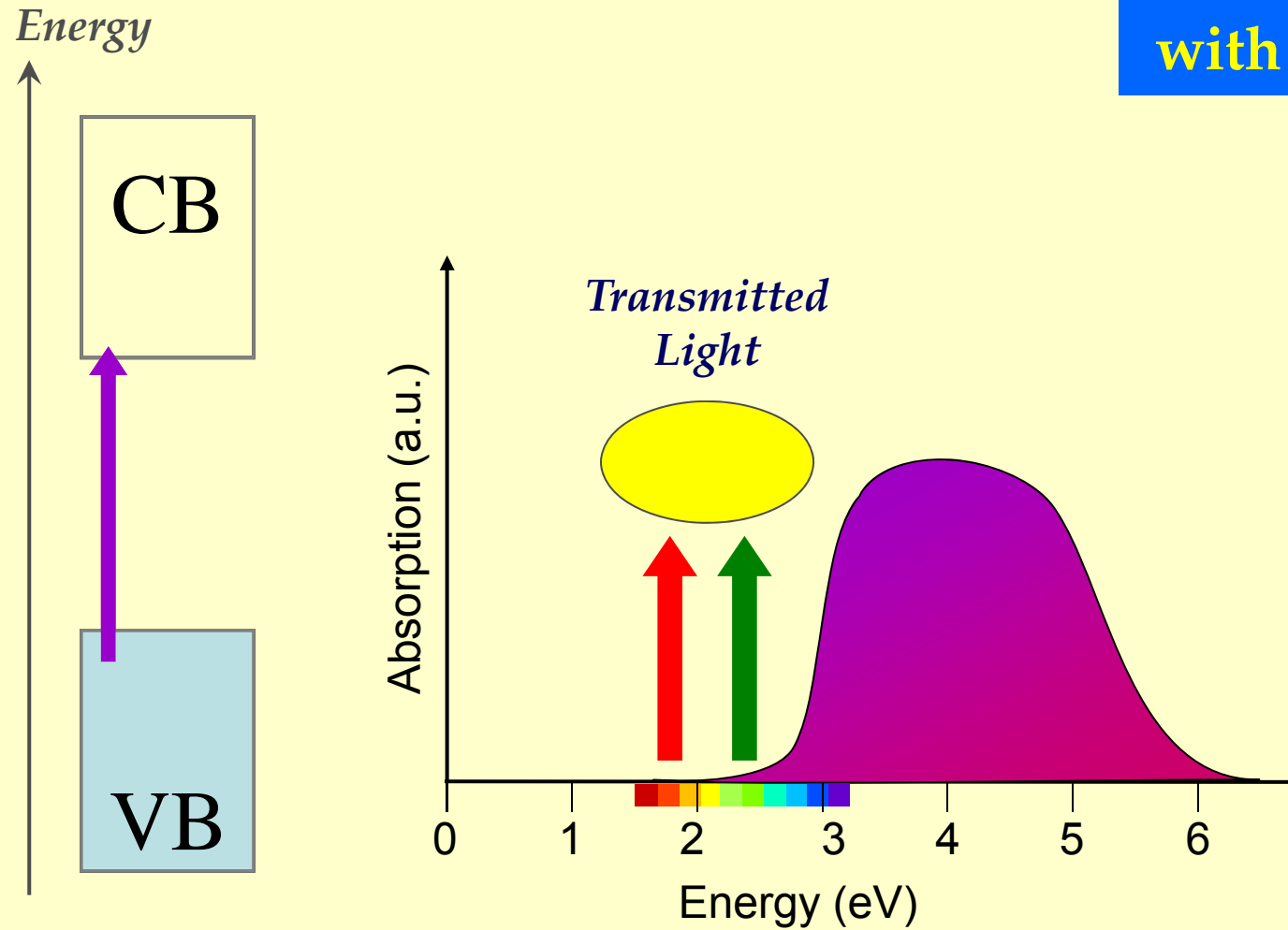

\*SC : Semiconductor

### 3 – UNDERSTANDING OF COLORS FROM BANDS

Color of a SC\*  
with several gaps

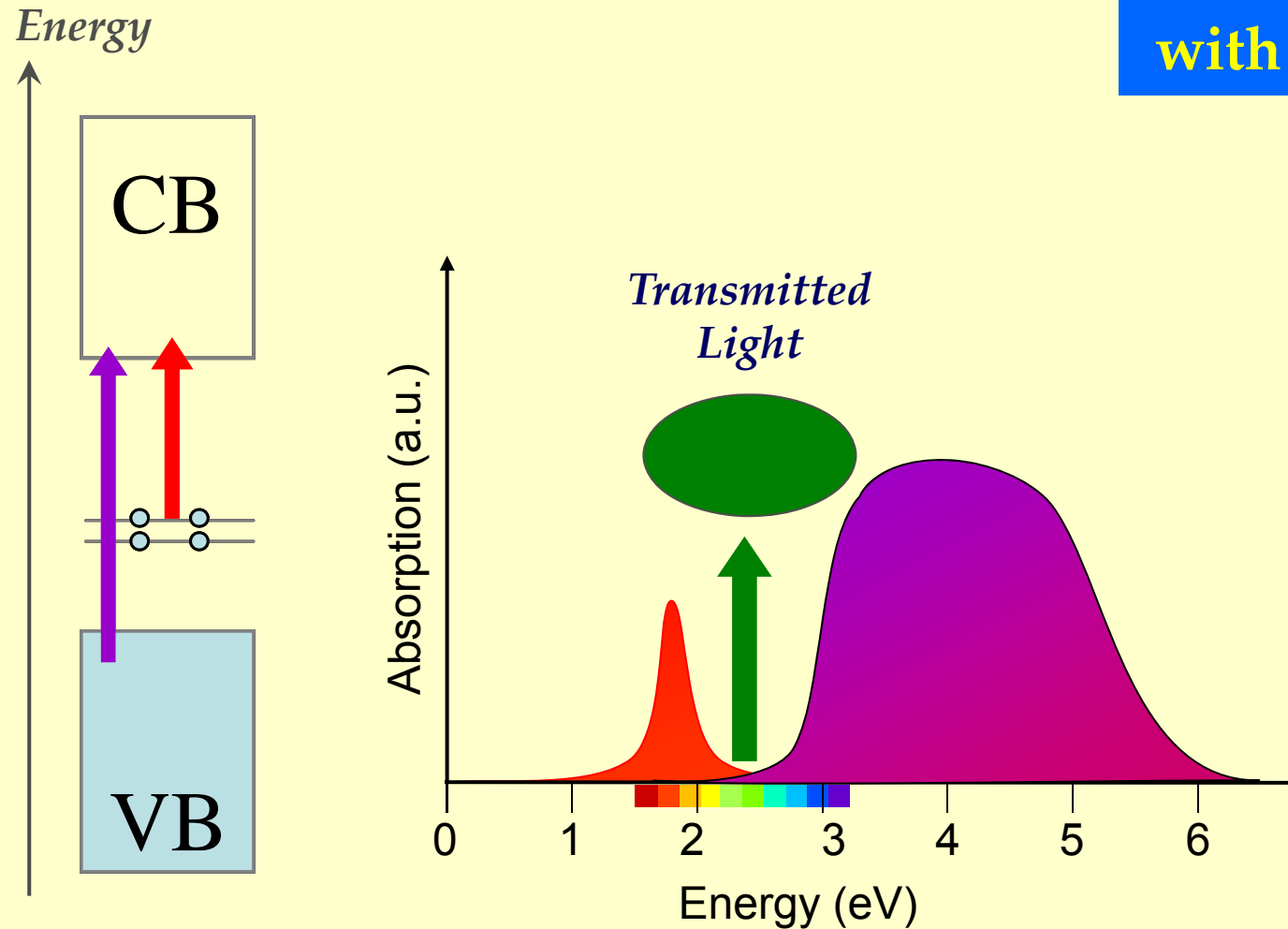

\*SC : Semi-conducteur – BI : Bande interdite



### 3 – UNDERSTANDING OF COLORS FROM BANDS

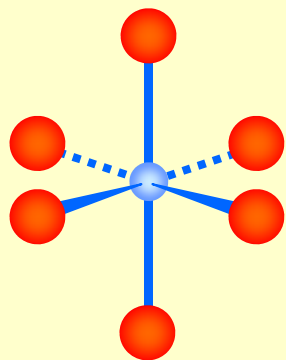

*Powder sample  
of  $TiO_2$  (rutile)*



**Charge transfer →  
color**

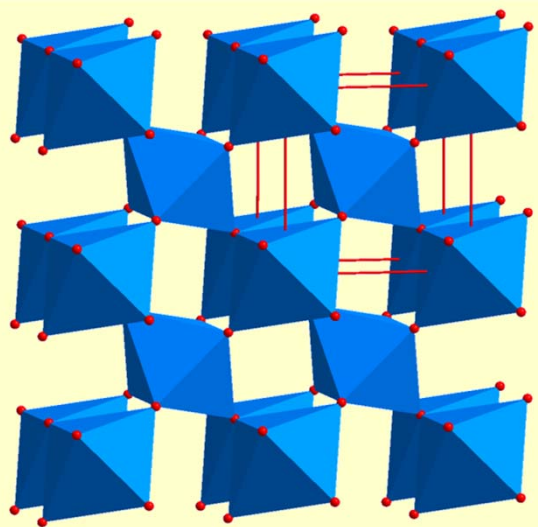

# 3 – UNDERSTANDING OF COLORS FROM BANDS

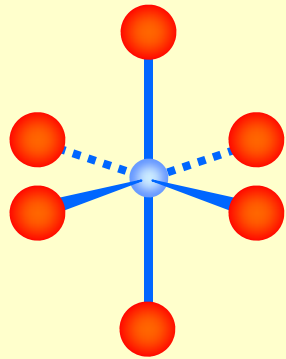

Powder sample  
of  $TiO_2$  (rutile)



Charge transfer →  
color

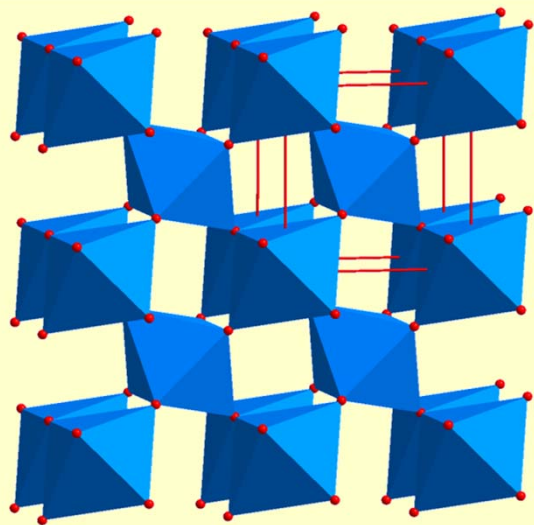
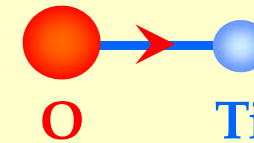

$Ti^{4+} (3d^0)$

$2 \times O^{2-} (2p^6)$

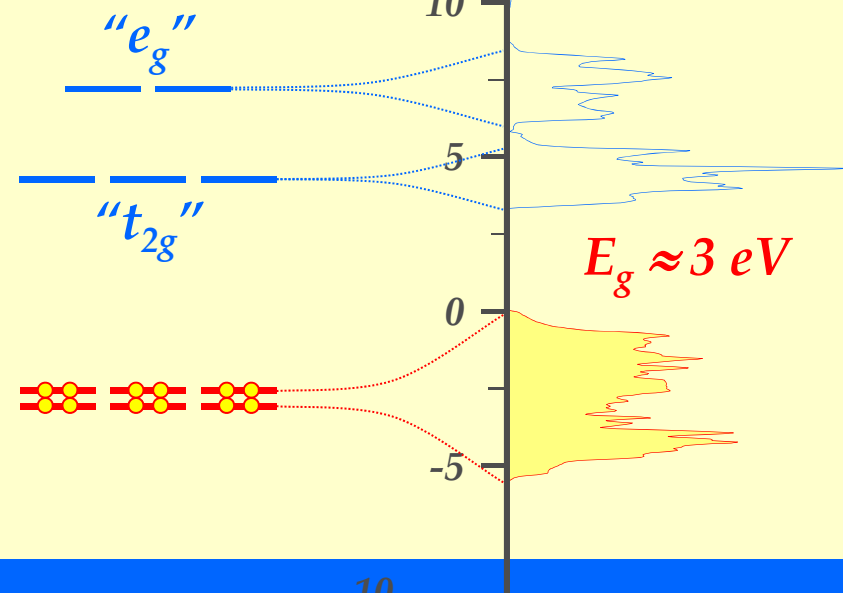

# 3 - UNDERSTANDING OF COLORS FROM BANDS

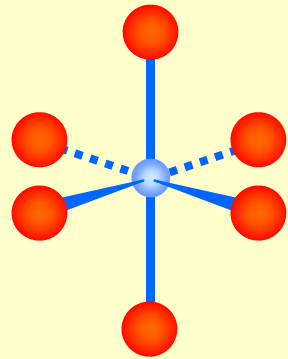

Absorption (a.u.)

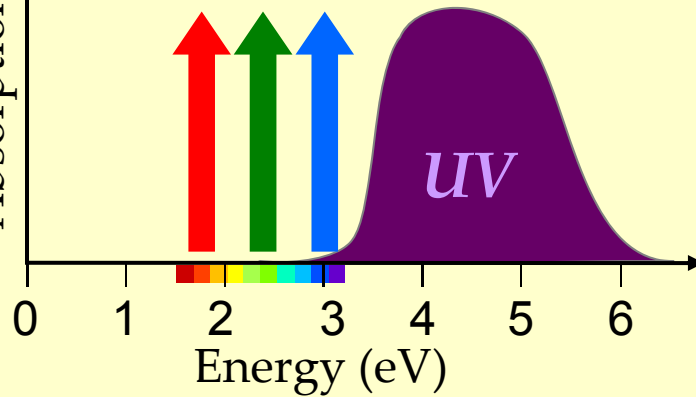

Charge transfer → color

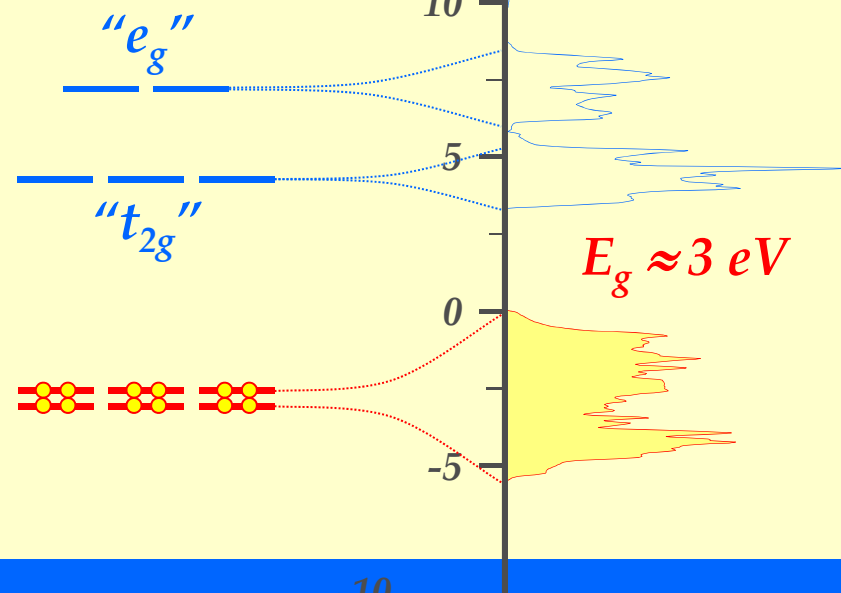
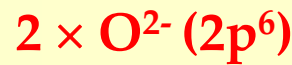
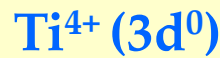
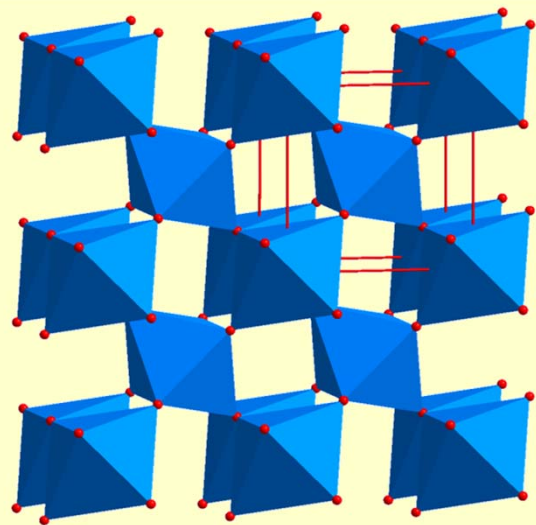
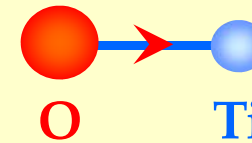

# 3 - UNDERSTANDING OF COLORS FROM BANDS

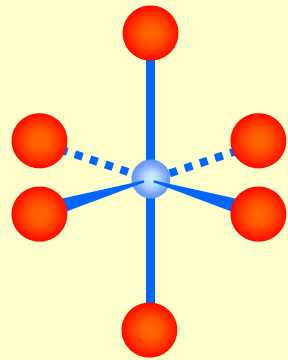

Absorption (a.u.)

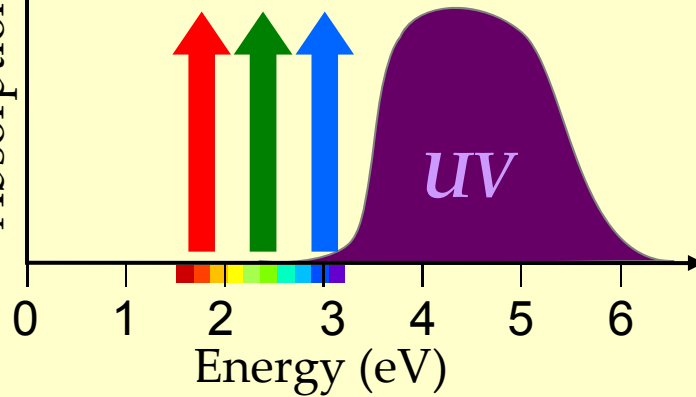

Charge transfer → color

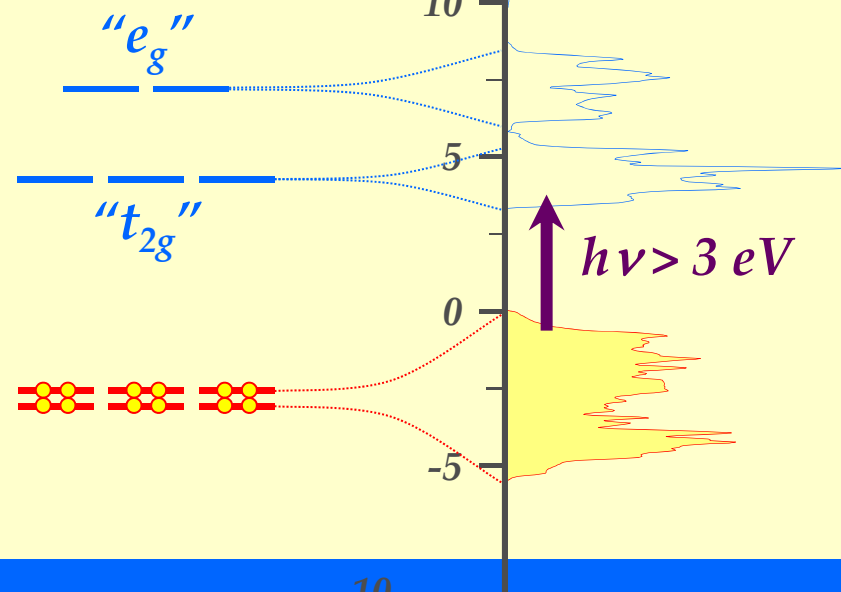
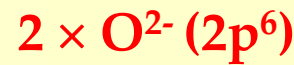
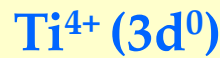
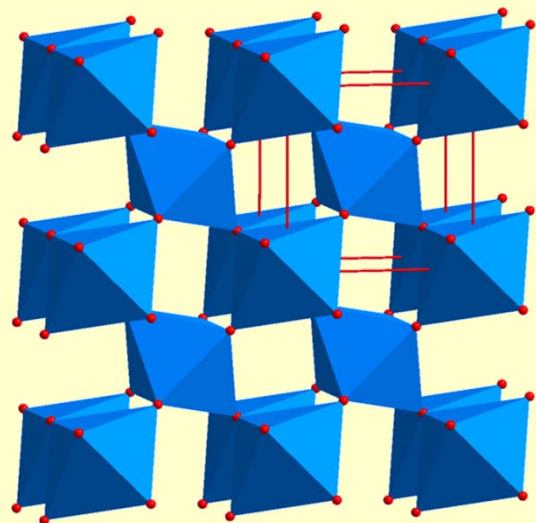
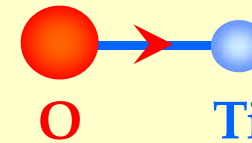

### 3 – UNDERSTANDING OF COLORS FROM BANDS

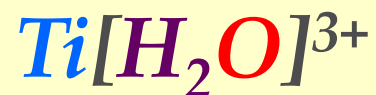
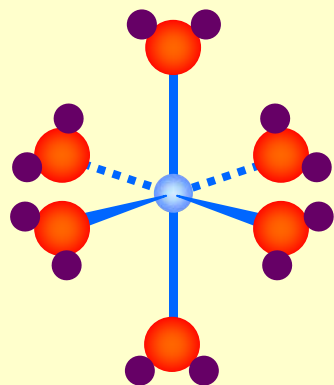

$TiCl_3$   
in solution



d-d transition  
→ color

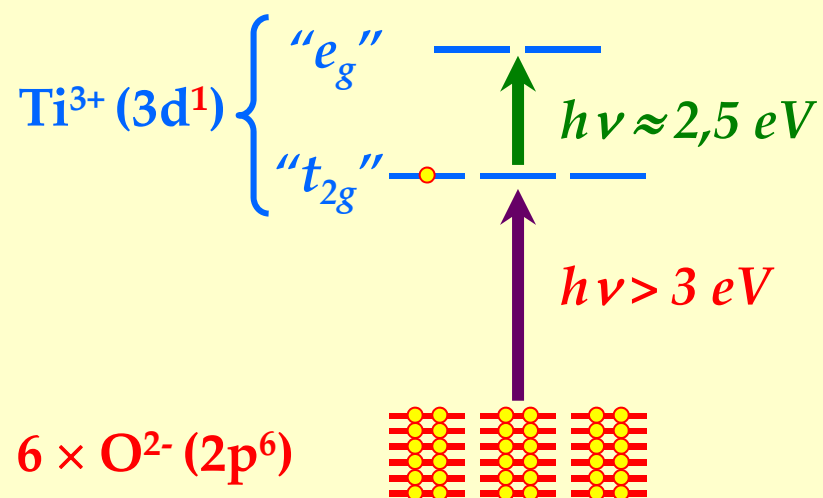

### 3 – UNDERSTANDING OF COLORS FROM BANDS

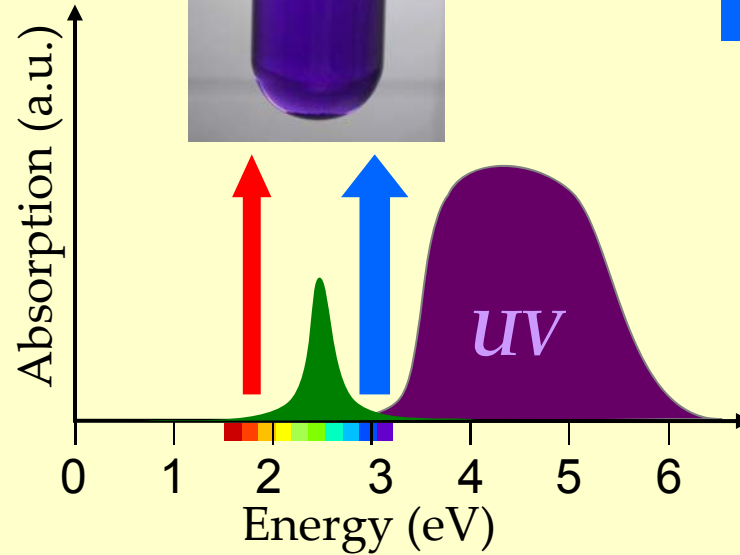
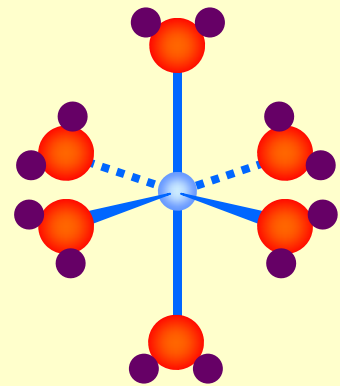

d-d transition  
→ color

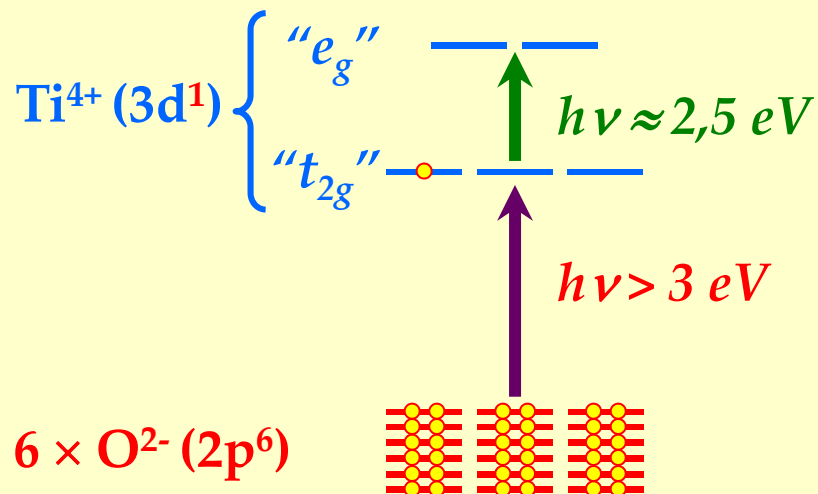
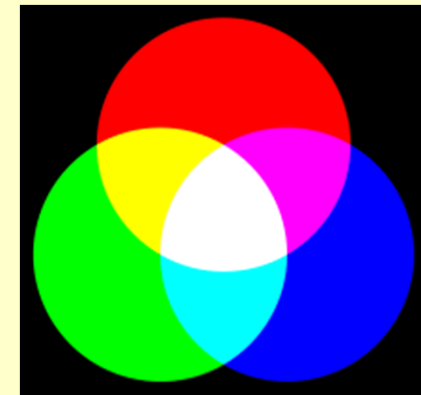

**Rq. : For  $d^n$  with  $n > 1$**

- Interelectronic correlations must be taken into account
- Tanabe-Sugano diagrams (spectroscopic terms)

### 3 – UNDERSTANDING OF COLORS FROM BANDS

Alumine  
corindon  
( $Al_2O_3$ )

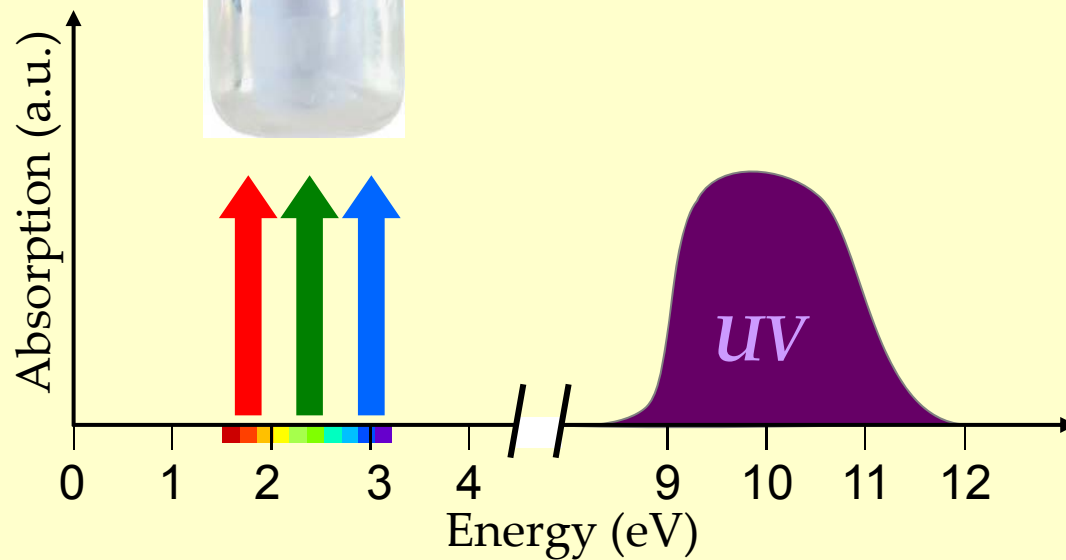

Energie

CB

VB



### 3 – UNDERSTANDING OF COLORS FROM BANDS

*Alumine  
corindon  
( $Al_2O_3$ )*



+ 1%  $Cr^{3+}$

*Synthetic  
rubis  
( $Al_2O_3:1\%Cr^{3+}$ )*

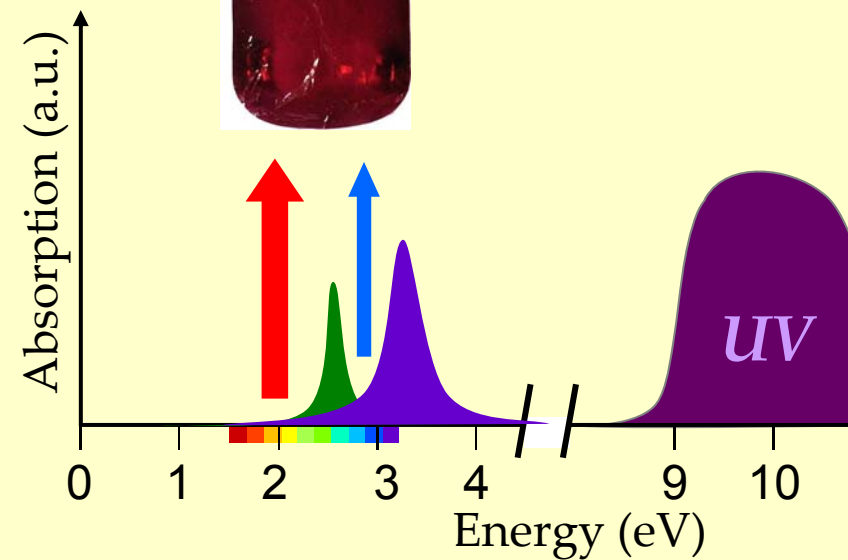
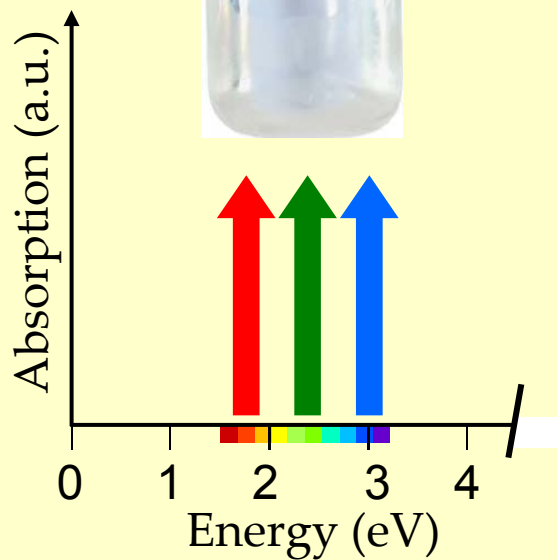



### 3 – UNDERSTANDING OF COLORS FROM BANDS

*Rubis*  
( $\text{Al}_2\text{O}_3:1\%\text{Cr}^{3+}$ )



Impurity (d-d)  
→ color

**$\text{Cr}^{3+}$  : electronic conf.  $d^3$**   
→ Interelectronic correlations must  
be taken into account  
→ Tanabe-Sugano diagrams  
(spectroscopic terms)

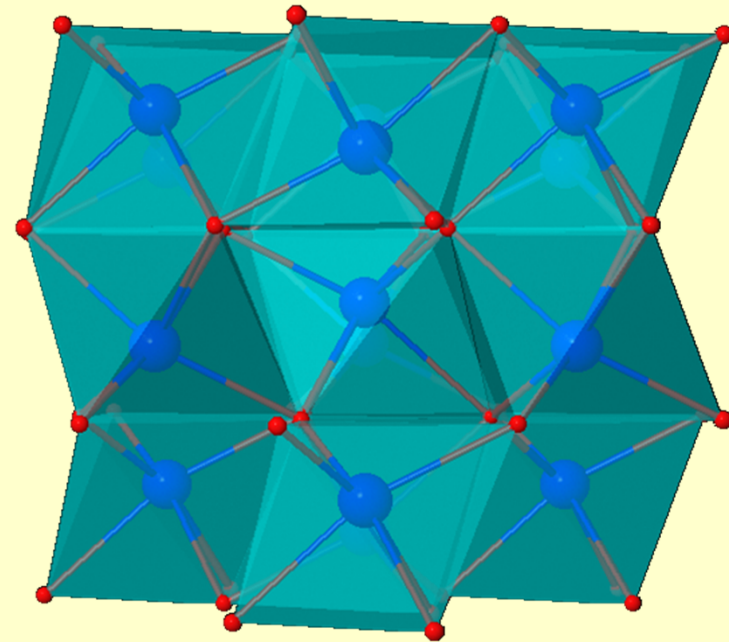

# 3 – UNDERSTANDING OF COLORS FROM BANDS

Rubis  
( $Al_2O_3:1\%Cr^{3+}$ )



Impurity (d-d)  
→ color

$Cr^{3+}$  : elect. conf.  $d^3$

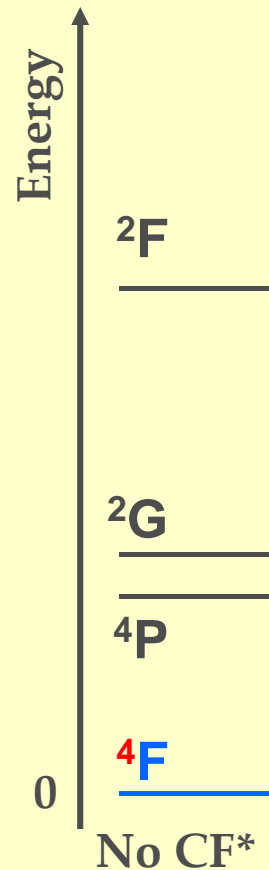

Free ion: we define the spectroscopic terms :

Multiplicity of spin →  $2S+1$   $\chi$

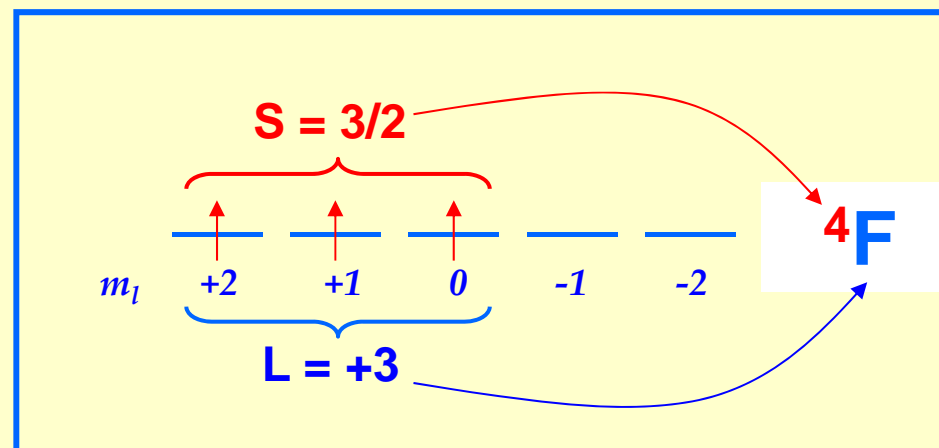

\*CF : Cristal Field

# 3 – UNDERSTANDING OF COLORS FROM BANDS

**Rubis**  
( $Al_2O_3:1\%Cr^{3+}$ )

**Impurity (d-d)**  
→ color

**Cr<sup>3+</sup> : conf. e<sup>g</sup> d<sup>3</sup>**

→ Degeneracy lifting due to the octahedral crystal field effect created by the ligands

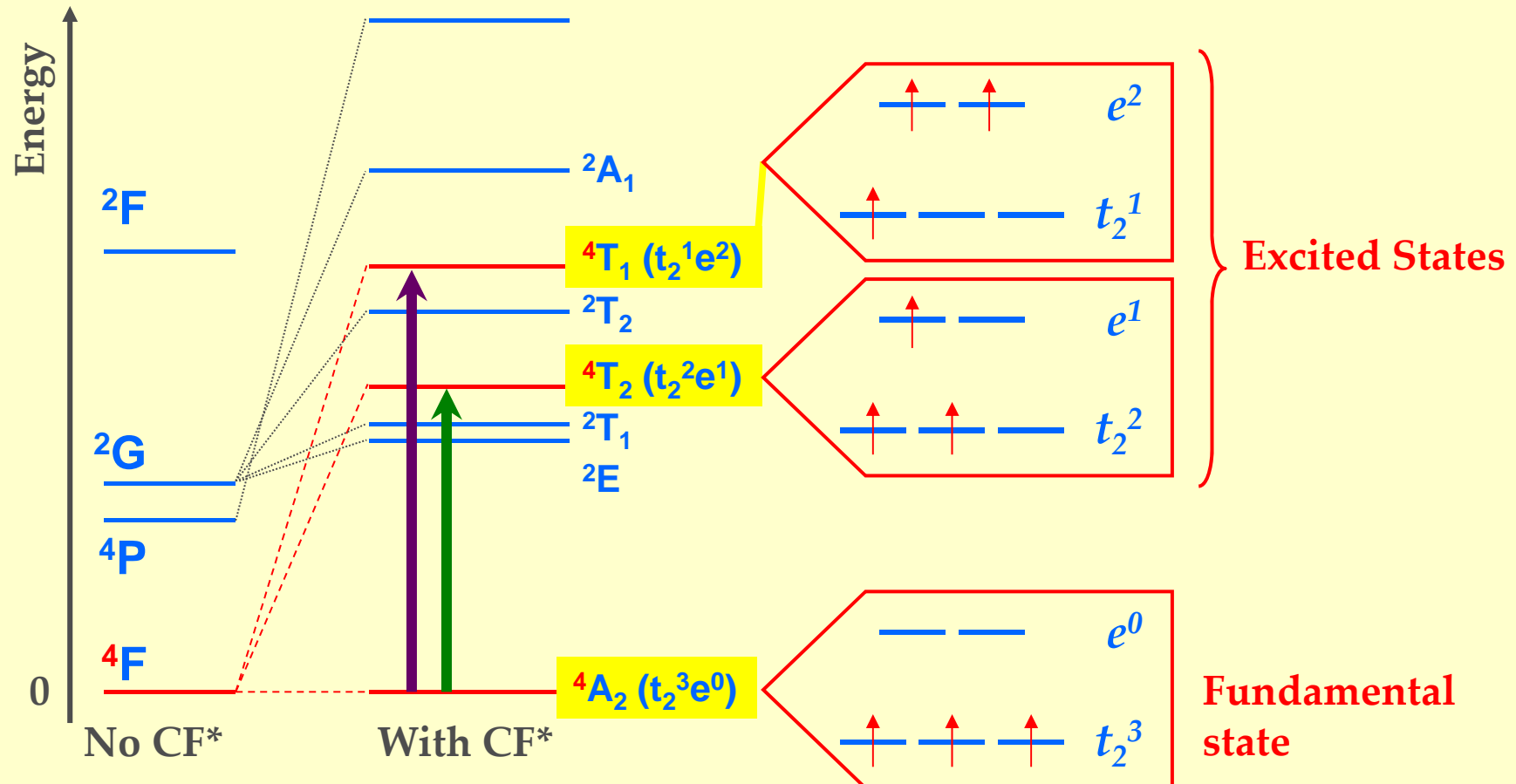

\*CF : Cristal Field

# 3 – UNDERSTANDING OF COLORS FROM BANDS

Rubis  
( $Al_2O_3:1\%Cr^{3+}$ )



Impurity (d-d)  
→ color

Red color  
+  
Slightly blue

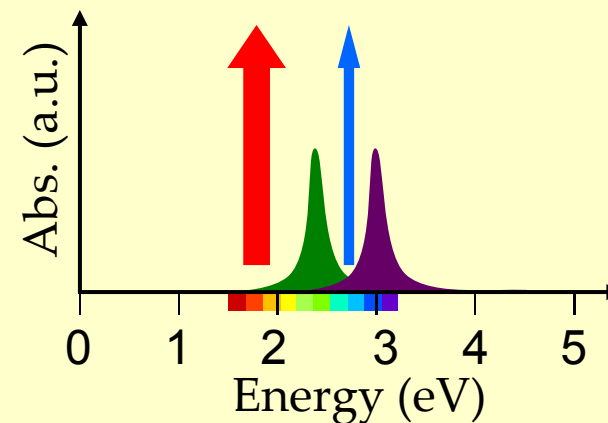
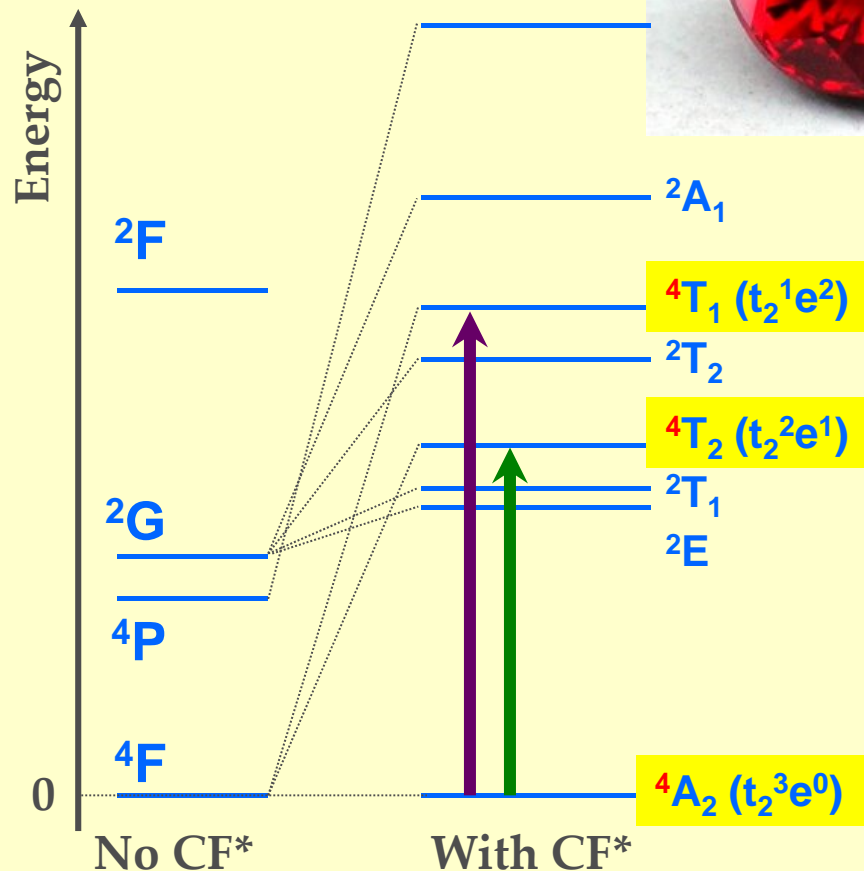

$Cr^{3+}$  : electronic conf.  $d^3$

- Interelectronic correlations must be taken into account
- Tanabe-Sugano diagrams (spectroscopic terms)

## 4 – LIGHT-MATTER INTERACTION

*Physical color → « Elastic diffusion »*

*Example of a prism*

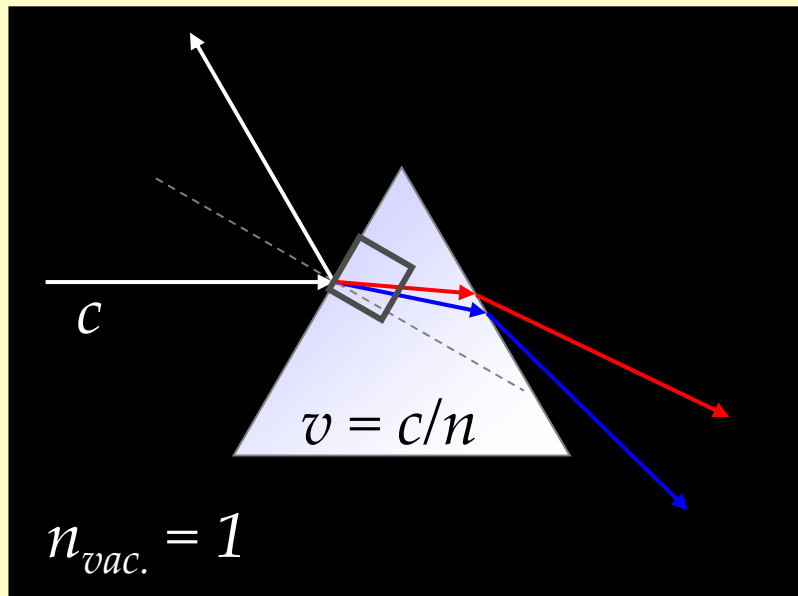

*$n$  : index of refraction*

*Propagation speed is changed*

# 4 – LIGHT-MATTER INTERACTION

*Physical color → « Elastic diffusion »*

*Example of a prism*

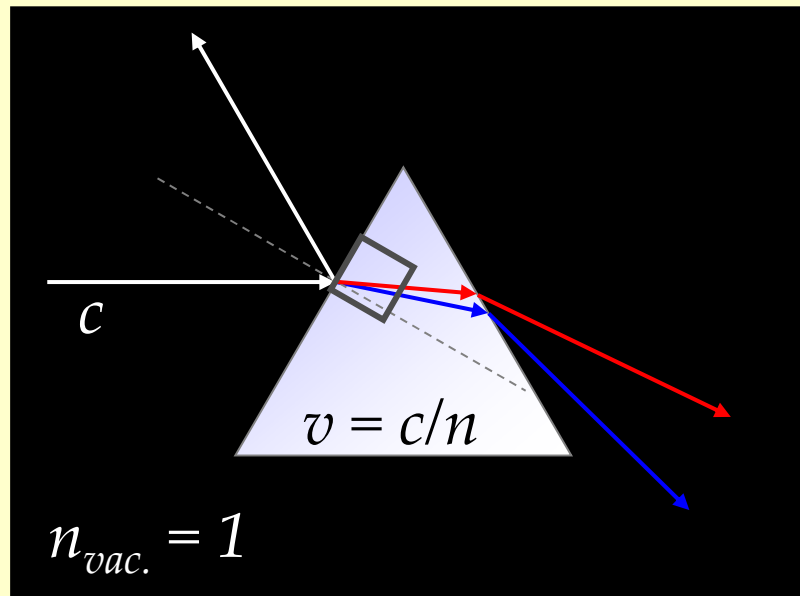

*Dipole moment*

$$\vec{\mu} = -e \cdot \vec{r}$$

*Elastic diffusion mechanism  
at the electronic level*

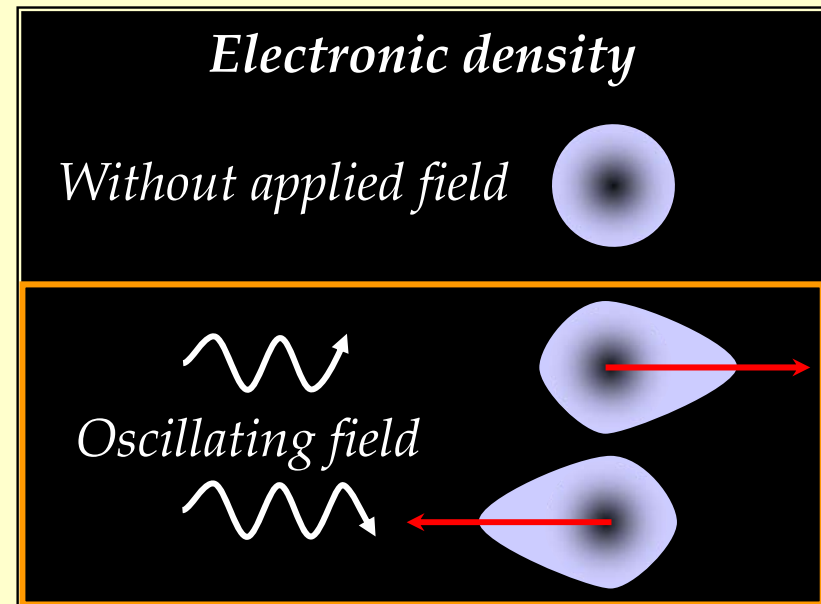

*Oscillating **Electric Field** polarize  $\rho$*

*→ : Inductive dipole moment ↔  
Receiver-transmitter **antenna***

*Succession of absorption and emission*

# 4 – LIGHT-MATTER INTERACTION

*Diffusion*

*Absorption*

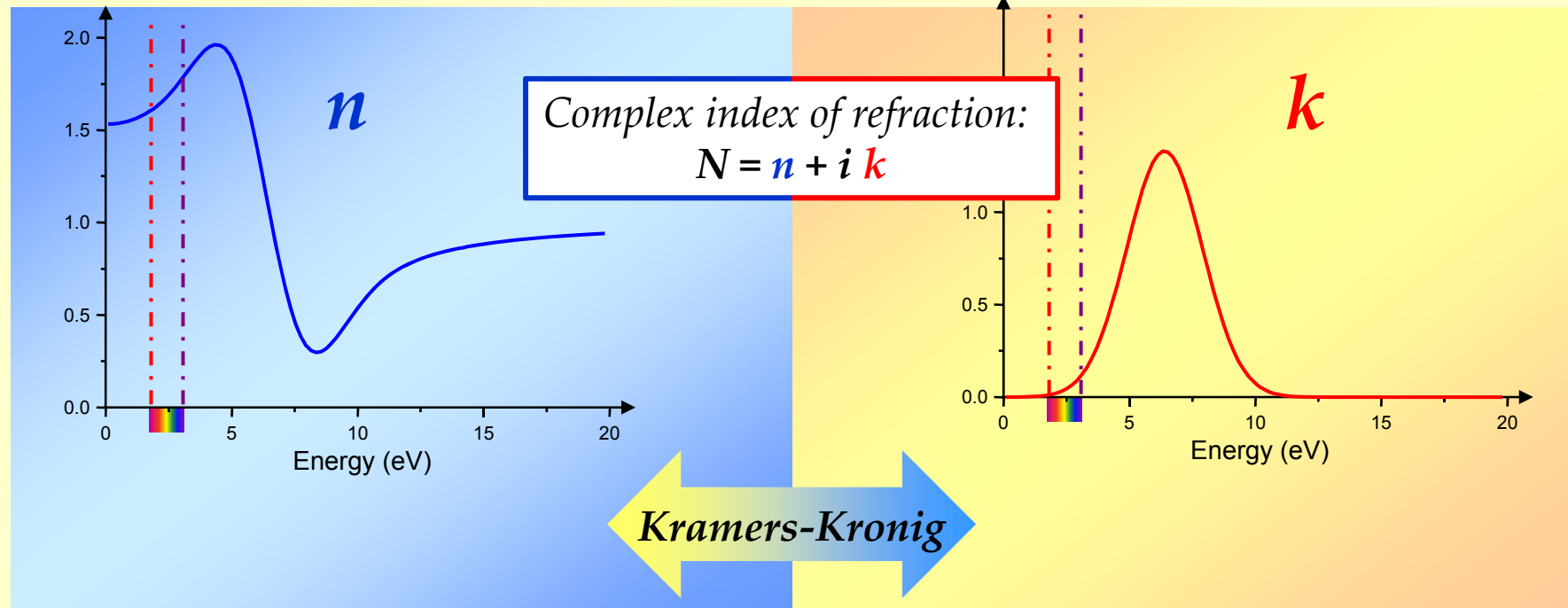

# 4 – LIGHT-MATTER INTERACTION

*Diffusion*

*Absorption*

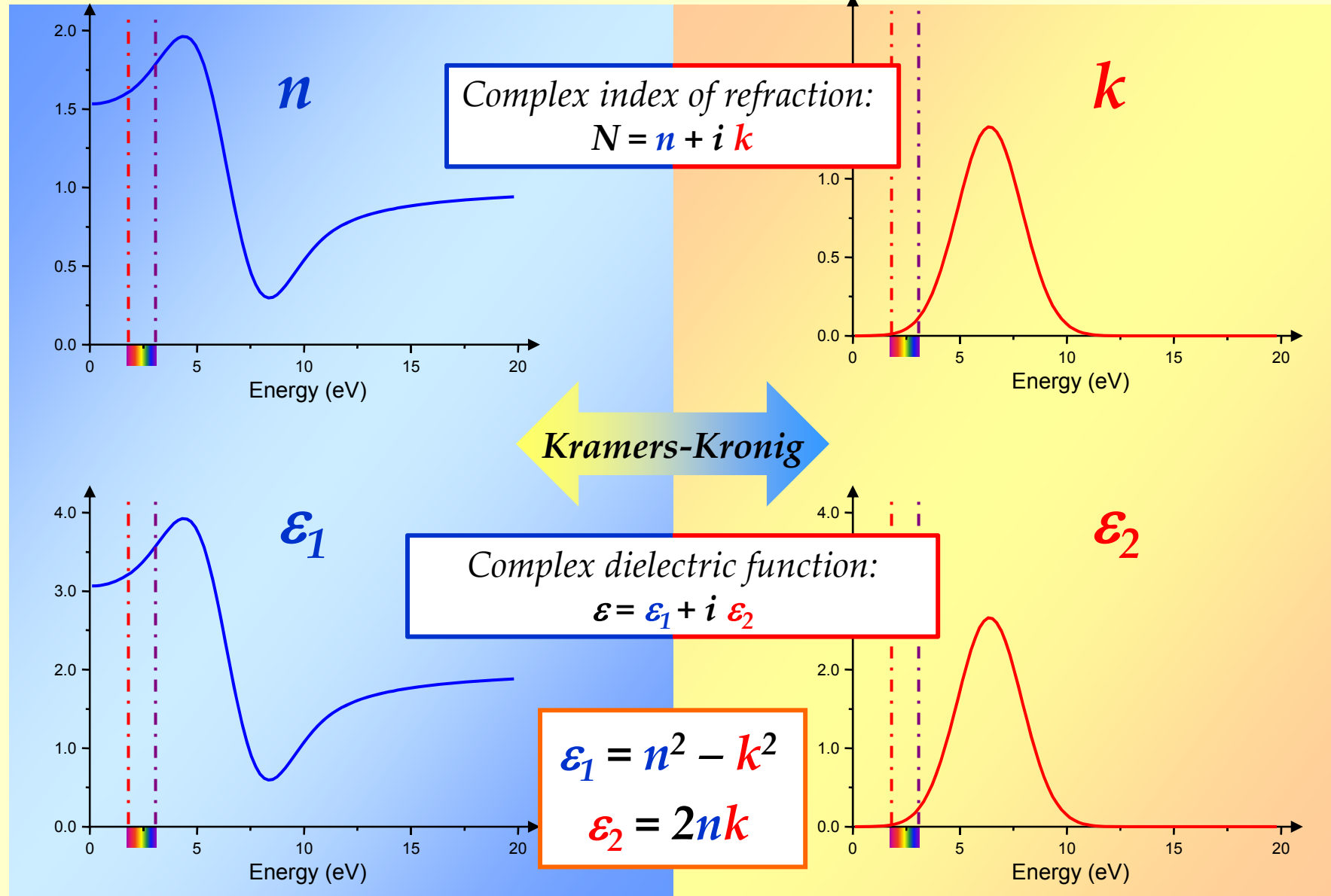



# 4 – LIGHT-MATTER INTERACTION

## Diffusion in the case of a prism

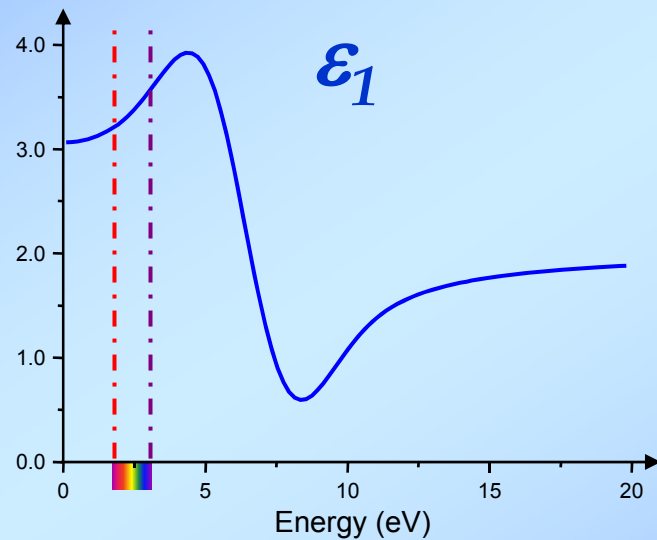
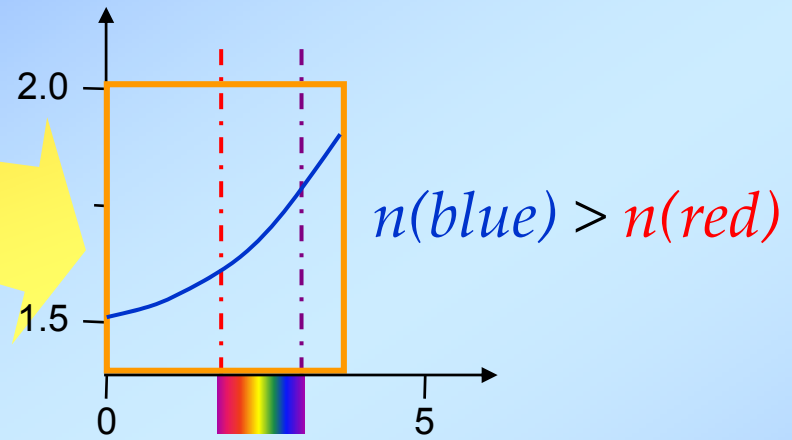
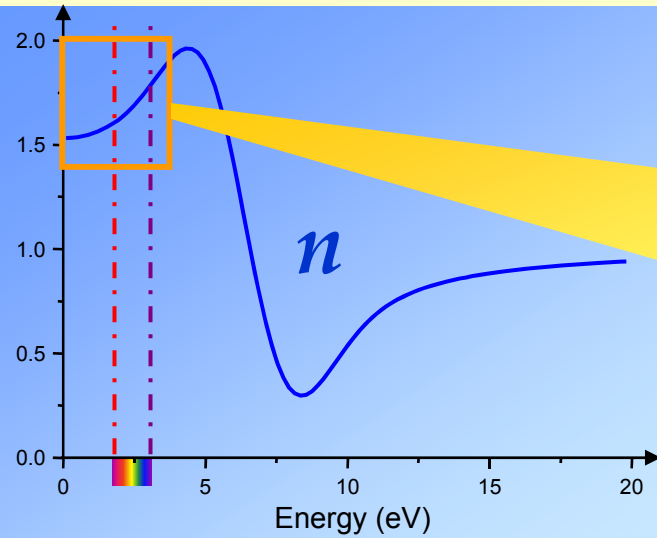

# 4 – LIGHT-MATTER INTERACTION

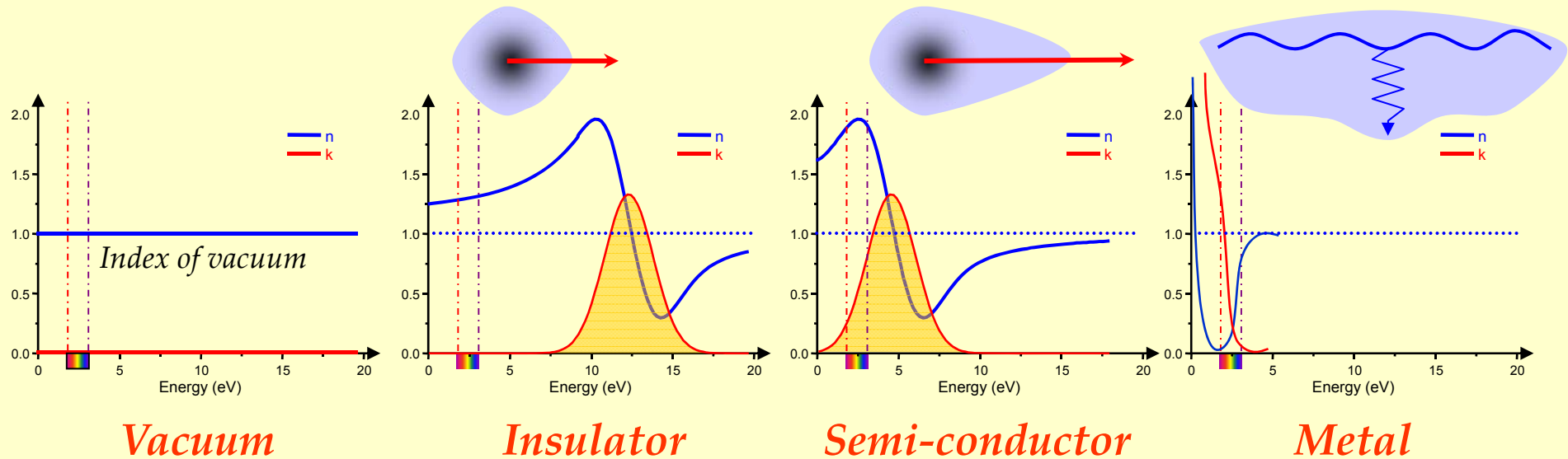

*Electron more and more free*

*Absorption band is displaced towards low energies*

*Directly related to the oscillator strength*

## 5 – OPTICAL PROPERTIES: WHICH TREATMENT?

The different steps to calculate the optical properties:

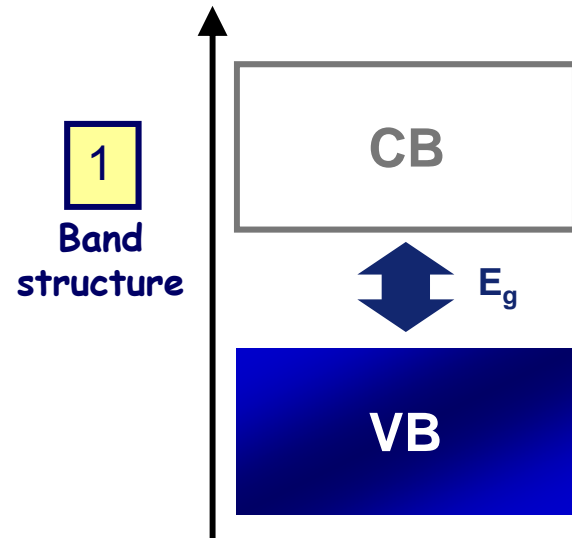

## 5 – OPTICAL PROPERTIES: WHICH TREATMENT?

The different steps to calculate the optical properties:

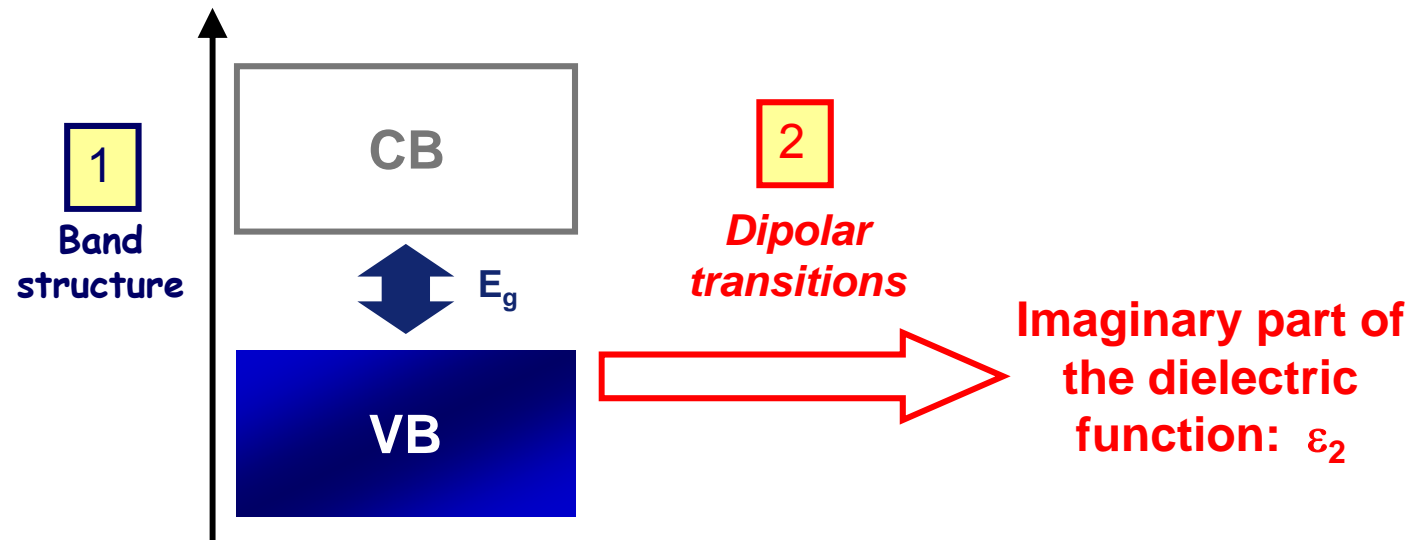

## 5 – OPTICAL PROPERTIES: WHICH TREATMENT?

The different steps to calculate the optical properties:

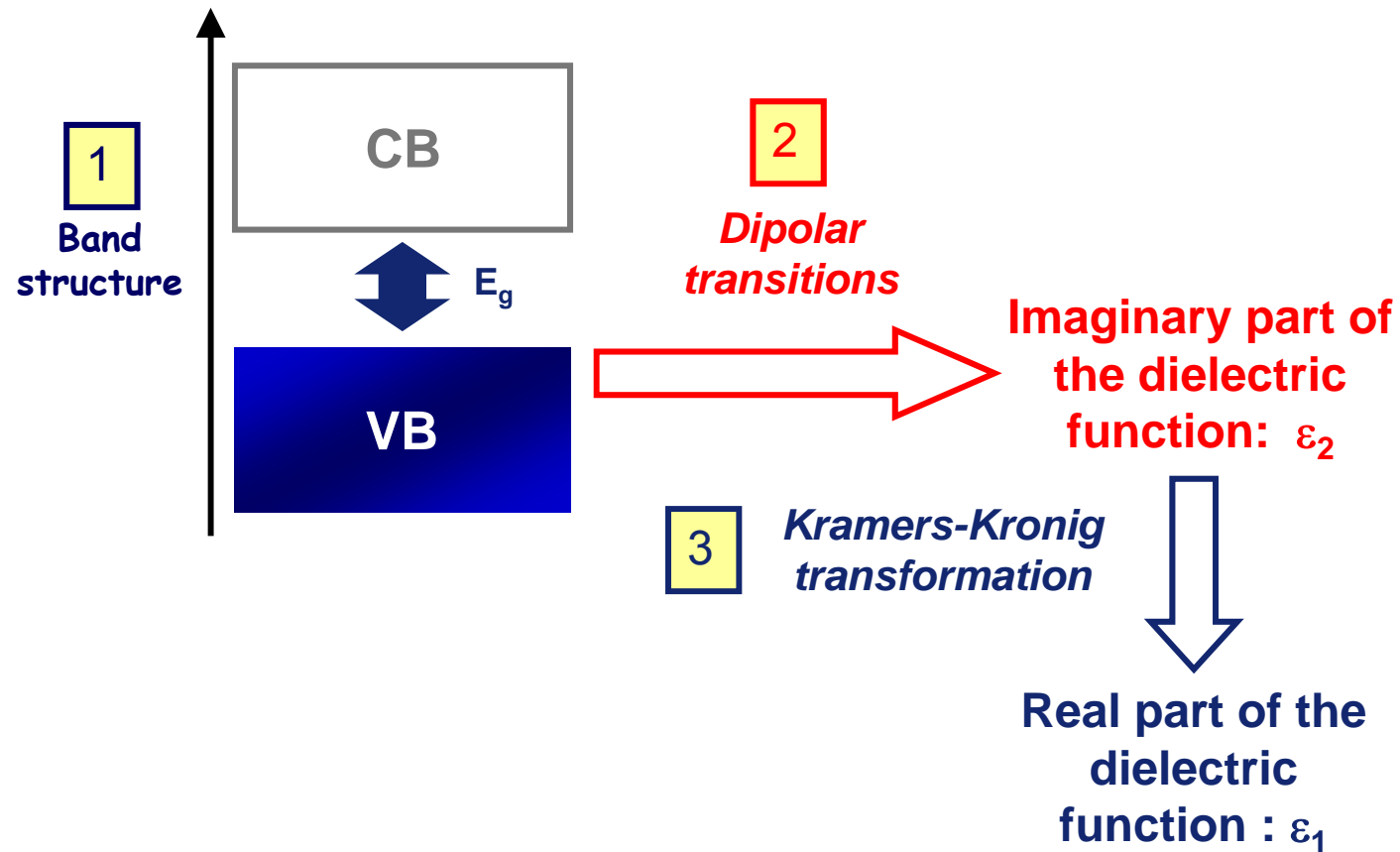

# 5 – OPTICAL PROPERTIES: WHICH TREATMENT?

The different steps to calculate the optical properties:

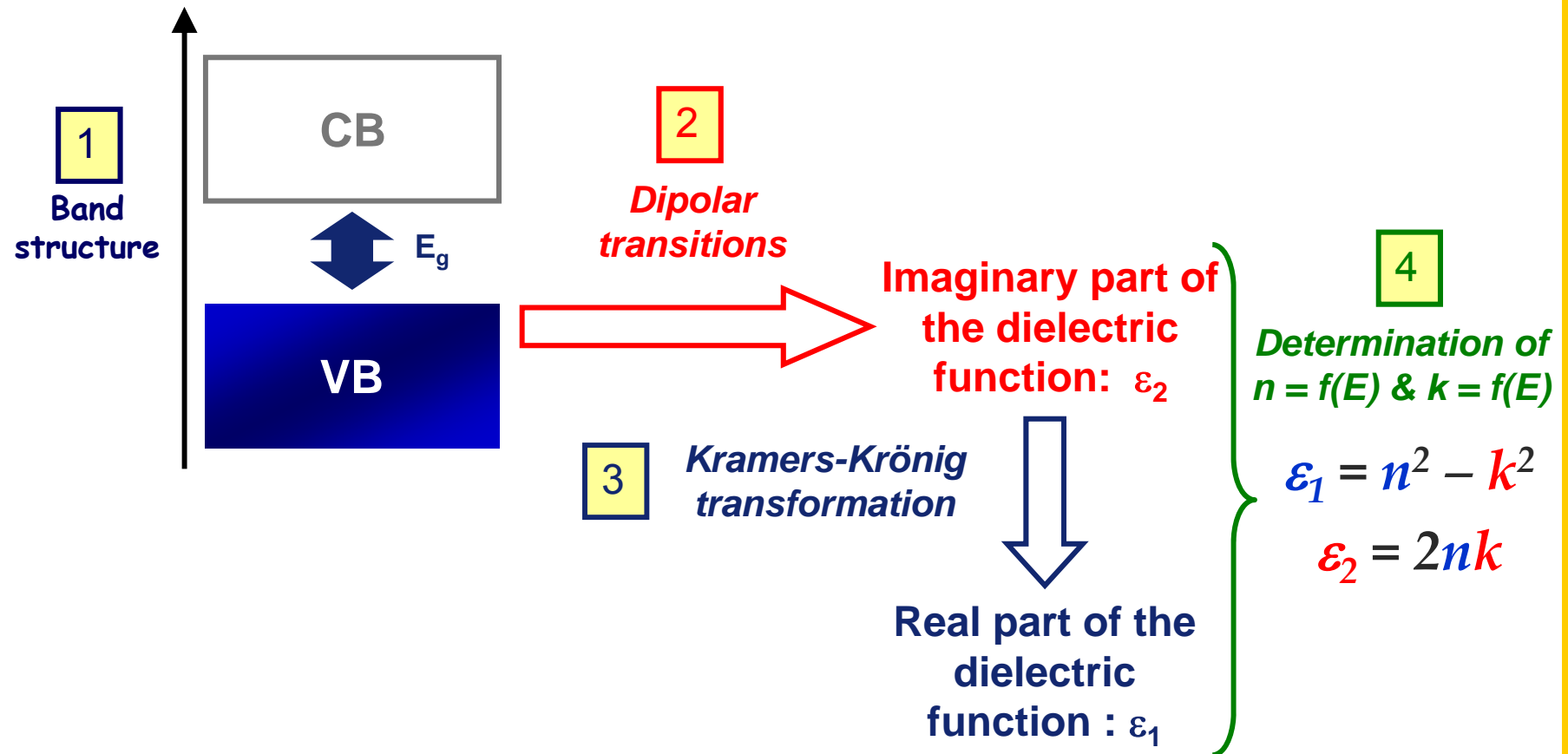

# 5 – OPTICAL PROPERTIES: WHICH TREATMENT?

## Example of $\text{BiVO}_4$

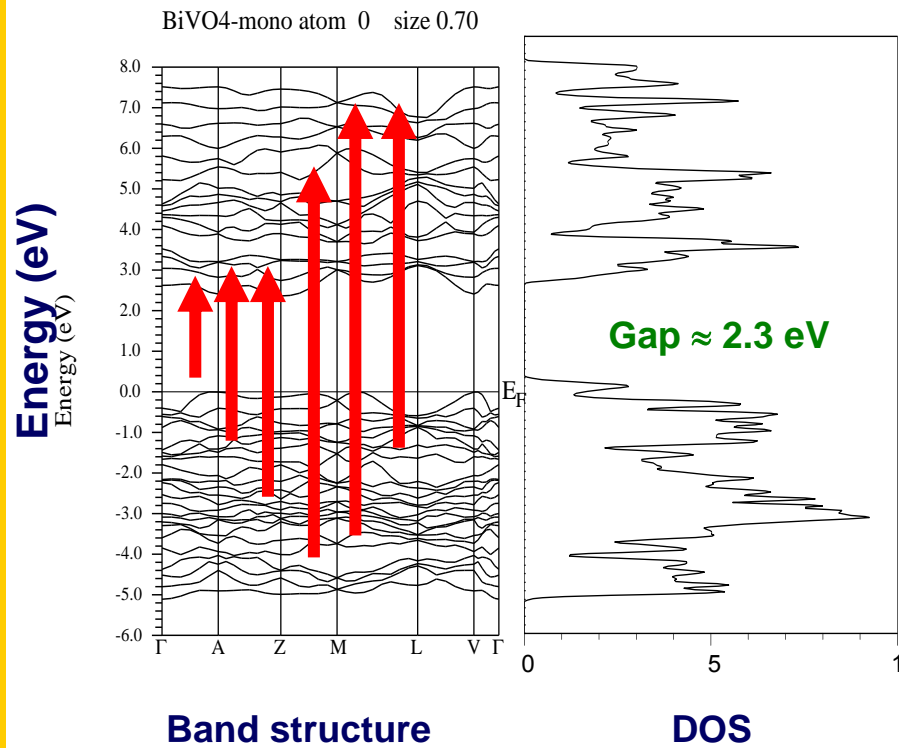

**1** Band structure calculation

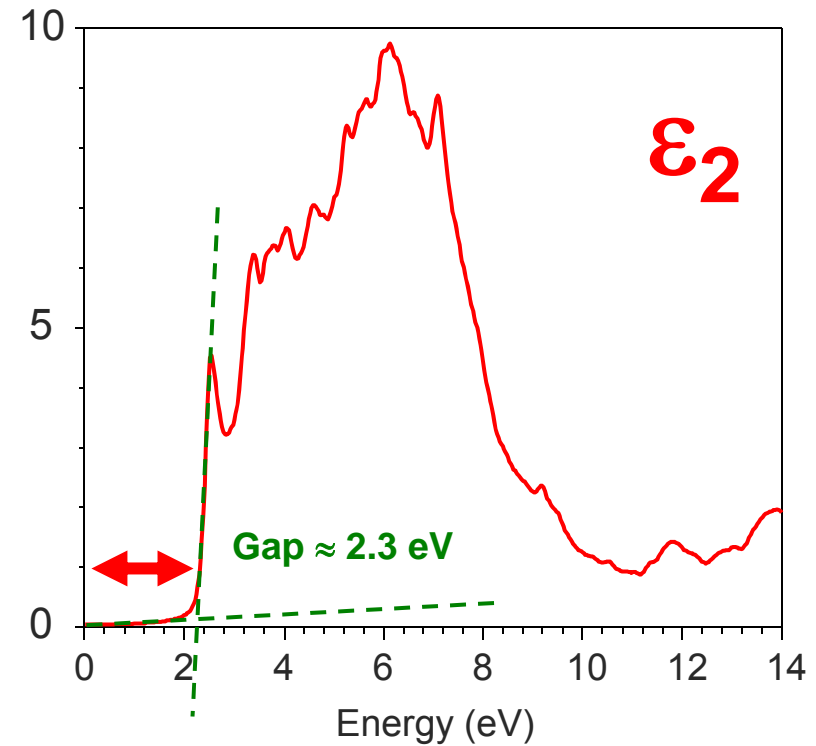

**2** Determination of  $\epsilon_2$

# 5 – OPTICAL PROPERTIES: WHICH TREATMENT?

## Example of $\text{BiVO}_4$

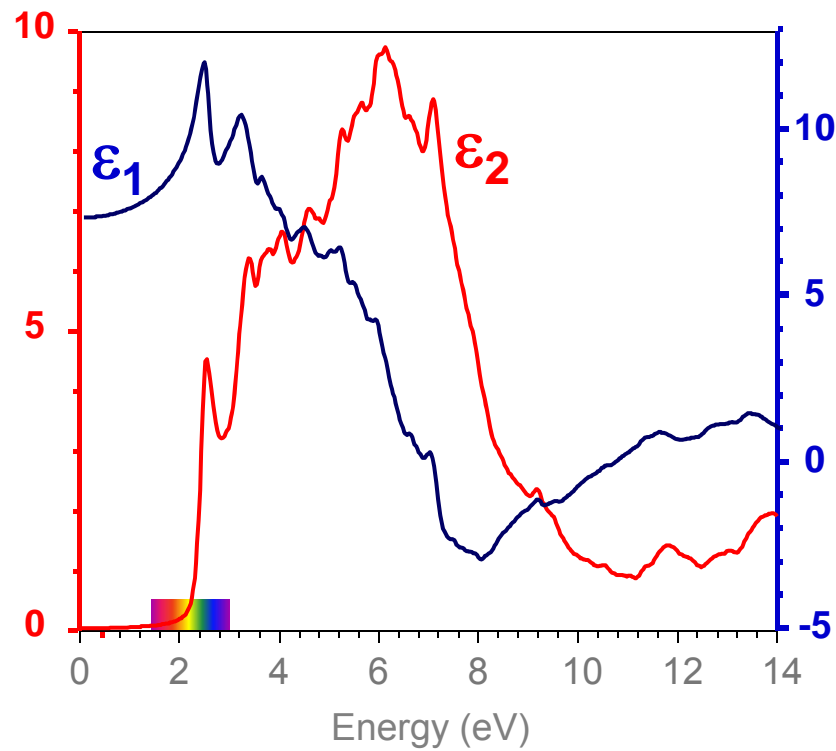

**3** Determination of  $\epsilon_1$

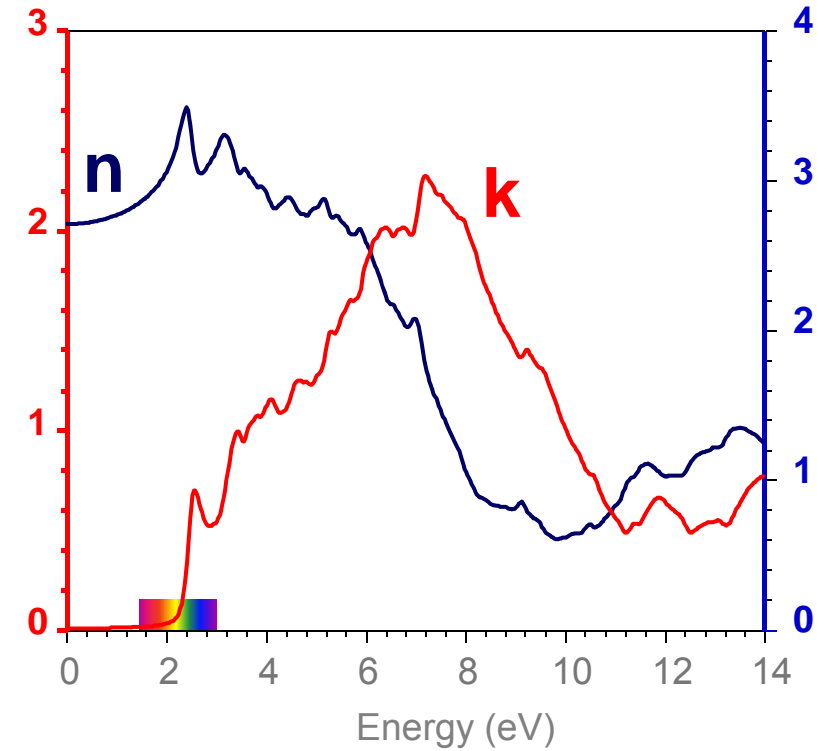

**4** Determination of  $n = f(E)$  &  $k = f(E)$



## 5 – OPTICAL PROPERTIES SIMULATION IN WIEN2k

In WIEN2k, two types of contributions to the dielectric function ( $\epsilon = \epsilon_1 + i.\epsilon_2$ ) could be estimated:

**Interband** contributions  
(based on IPA\*)

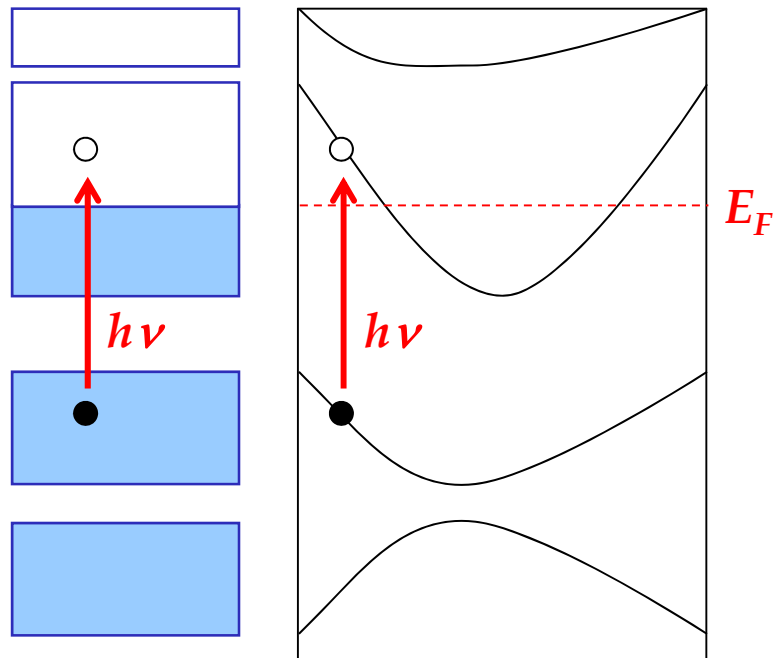

**Intraband** contributions  
(using a Drude-like term)

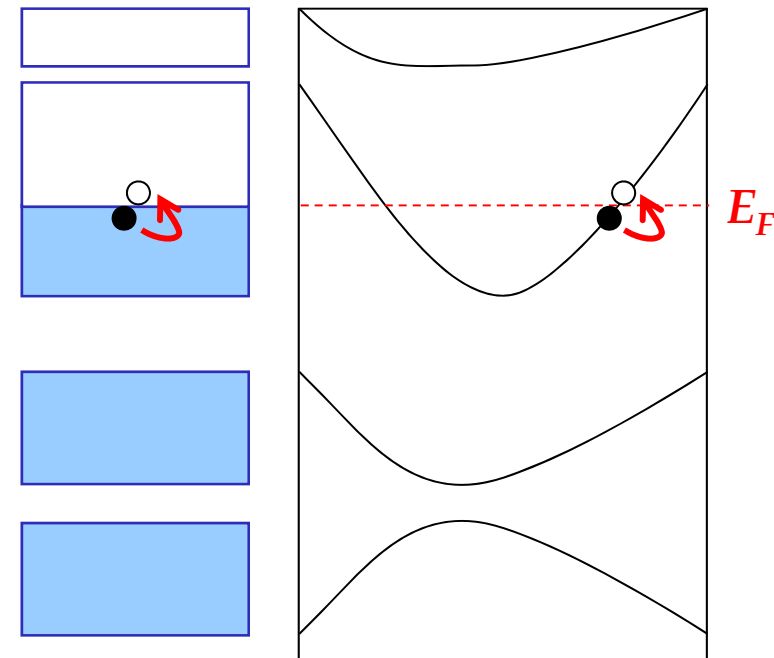

→ Dielectric tensor / Optical conductivity / Refractive index /  
Reflectivity / Absorption coefficient / Loss function (EELS)

\*IPA: Independant Particle Approximation

## 5 – OPTICAL PROPERTIES SIMULATION IN WIEN2k

In WIEN2k, two types of contributions to the dielectric function ( $\epsilon = \epsilon_1 + i.\epsilon_2$ ) could be estimated:

*Interband* contributions  
(based on IPA\*)

Sum over all valence and conduction bands

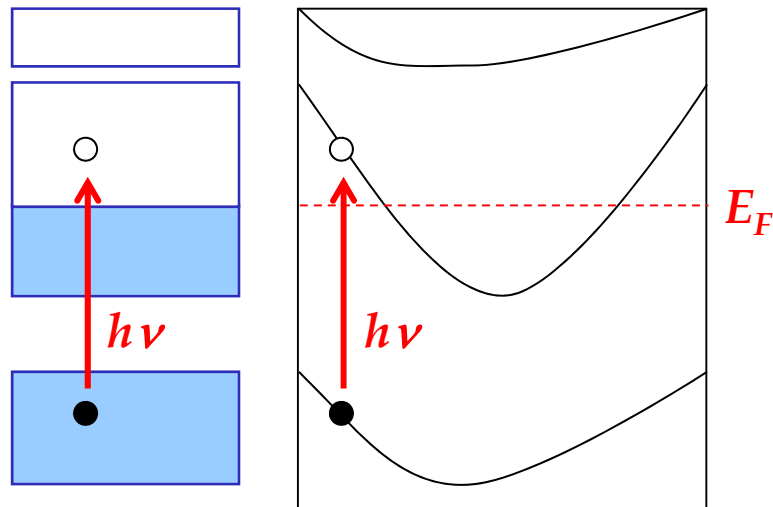

joint density of states

$$\sum_{vck} \delta(\epsilon_{kc} - \epsilon_{vk} - \omega)$$

transition probability

$$\text{Im}(\epsilon_{ij}(\omega)) = \frac{16\pi^2}{\Omega\omega^2} \sum_{vck} \langle vk | p_i | ck \rangle \langle ck | p_j | vk \rangle \delta(\epsilon_{kc} - \epsilon_{vk} - \omega)$$

\*IPA: Independant Particle Approximation

## 5 – INTERPRETATION: Intraband transitions (for metals)

**intraband:** Drude model,  
( $\omega_p$ : plasma frequency)

$$\text{Im } \epsilon^{\text{intra}} = \frac{\Gamma \omega_p^2}{\omega (\omega^2 + \Gamma^2)}$$

**Plasma frequency:** (longitudinal  
oscillations of the electron gas)

*Intraband contributions*  
(using a Drude-like term)

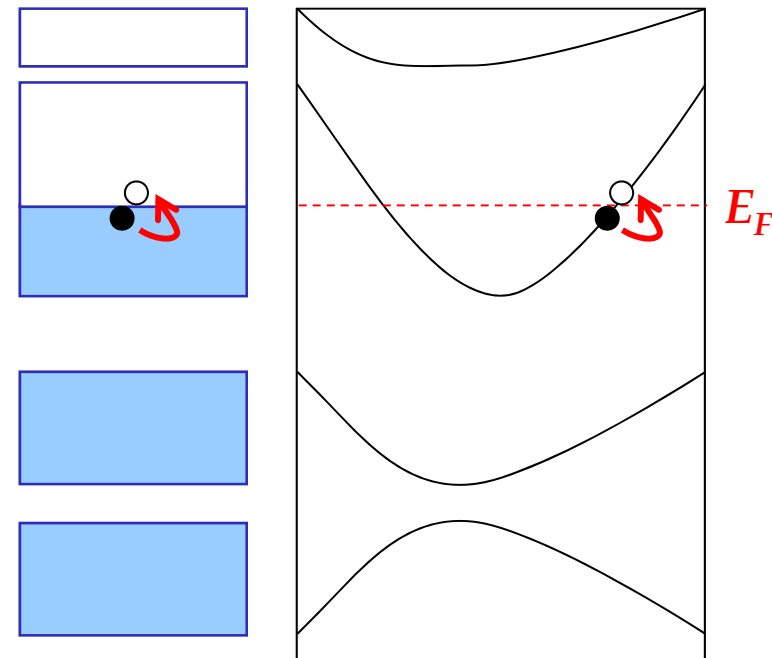

$$\omega_{p,\alpha\beta}^2 = \frac{4\pi e^2}{\Omega^2} \left( \frac{n}{m} \right)_{\alpha\beta} = \frac{e^2}{m^2 \pi^2} \sum_l \int d\mathbf{k} \langle l | p^\alpha | l \rangle_{\mathbf{k}} \langle l | p^\beta | l \rangle_{\mathbf{k}} \delta(\epsilon_l - \epsilon_F)$$

## 5 – OPTICAL PROPERTIES SIMULATION IN WIEN2k

### Optical functions:

- Dielectric tensor  $\Im \epsilon_{ij} = \frac{16\pi^2}{\Omega \omega^2} \sum_{vck} \langle vk | p_i | ck \rangle \langle ck | p_j | vk \rangle \delta(\epsilon_{kc} - \epsilon_{vk} - \omega)$   
 $\Re \epsilon_{ij} = \delta_{ij} \frac{2}{\pi} P \int_0^\infty \frac{\omega' \Im \epsilon_{ij}(\omega')}{\omega'^2 - \omega^2} d\omega'$
- Optical conductivity  $\Re \sigma_{ij}(\omega) = \frac{\omega}{4\pi} \Im \epsilon_{ij}(\omega)$
- Refractive index  $n_{ii} = \sqrt{\frac{|\epsilon_{ii}(\omega)| + \Re \epsilon_{ii}(\omega)}{2}}$   $k_{ii}(\omega) = \sqrt{\frac{|\epsilon_{ii}(\omega)| - \Re \epsilon_{ii}(\omega)}{2}}$
- Reflectivity  $R_{ii}(\omega) = \frac{(m_{ii} - 1)^2 + k_{ii}^2}{(n_{ii} + 1)^2 + k_{ii}^2}$
- Absorption  $A_{ii}(\omega) = \frac{2\omega k_{ii}(\omega)}{c}$
- Loss function  $L_{ii}(\omega) = -\Im \left( \frac{1}{\epsilon_{ii}(\omega)} \right)$

## 5 – OPTICAL PROPERTIES SIMULATION IN WIEN2k

### *Symmetry of the dielectric tensor*

$$\textit{triclinic} \quad \begin{pmatrix} \text{Im } \epsilon_{xx} & \text{Im } \epsilon_{xy} & \text{Im } \epsilon_{xz} \\ \text{Im } \epsilon_{xy} & \text{Im } \epsilon_{yy} & \text{Im } \epsilon_{yz} \\ \text{Im } \epsilon_{xz} & \text{Im } \epsilon_{yz} & \text{Im } \epsilon_{zz} \end{pmatrix}$$

*monoclinic* ( $\alpha, \beta = 90^\circ$ )

$$\begin{pmatrix} \text{Im } \epsilon_{xx} & \text{Im } \epsilon_{xy} & 0 \\ \text{Im } \epsilon_{xy} & \text{Im } \epsilon_{yy} & 0 \\ 0 & 0 & \text{Im } \epsilon_{zz} \end{pmatrix}$$

*orthorhombic*

$$\begin{pmatrix} \text{Im } \epsilon_{xx} & 0 & 0 \\ 0 & \text{Im } \epsilon_{yy} & 0 \\ 0 & 0 & \text{Im } \epsilon_{zz} \end{pmatrix}$$

*tetragonal, hexagonal*

$$\begin{pmatrix} \text{Im } \epsilon_{xx} & 0 & 0 \\ 0 & \text{Im } \epsilon_{xx} & 0 \\ 0 & 0 & \text{Im } \epsilon_{zz} \end{pmatrix}$$

*cubic*

$$\begin{pmatrix} \text{Im } \epsilon_{xx} & 0 & 0 \\ 0 & \text{Im } \epsilon_{xx} & 0 \\ 0 & 0 & \text{Im } \epsilon_{xx} \end{pmatrix}$$

## 5 – OPTICAL PROPERTIES SIMULATION IN WIEN2k

*Convergence with k-mesh (expl.: Al)*

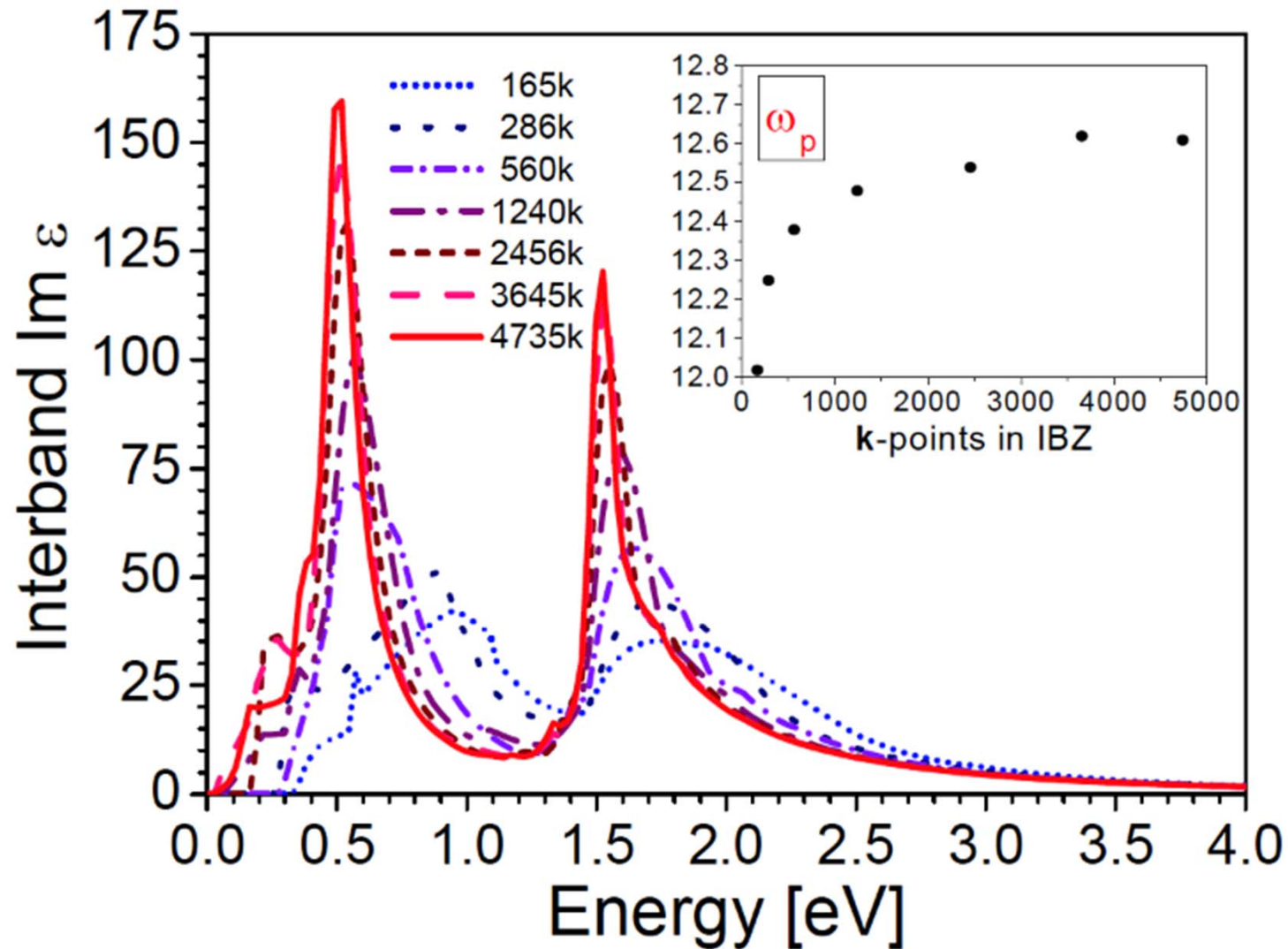

## 6 – ILLUSTRATIONS: $\text{TiO}_2$ series

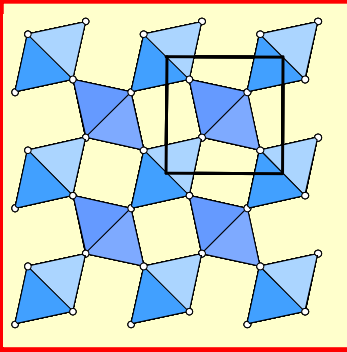

*Example of the rutile phase*

*Atomic structure*



*Electronic structure*



*Dielectric function*

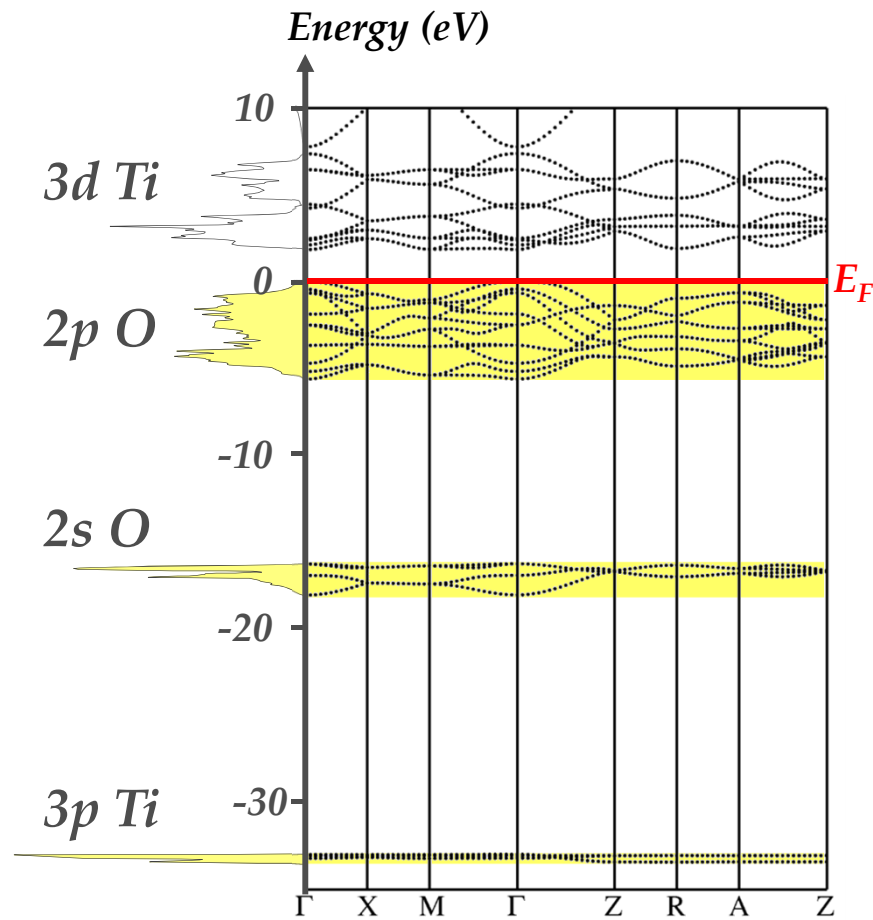

## 6 – ILLUSTRATIONS: $\text{TiO}_2$ series

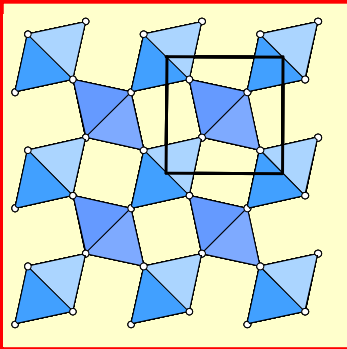

*Example of the rutile phase*

*Atomic structure*



*Electronic structure*



*Dielectric function*

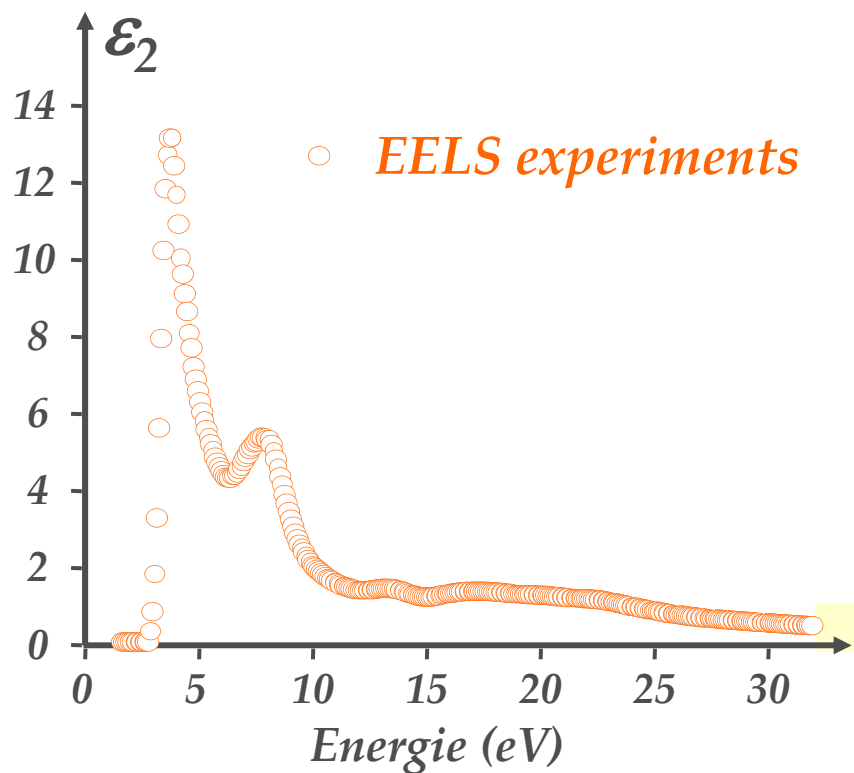
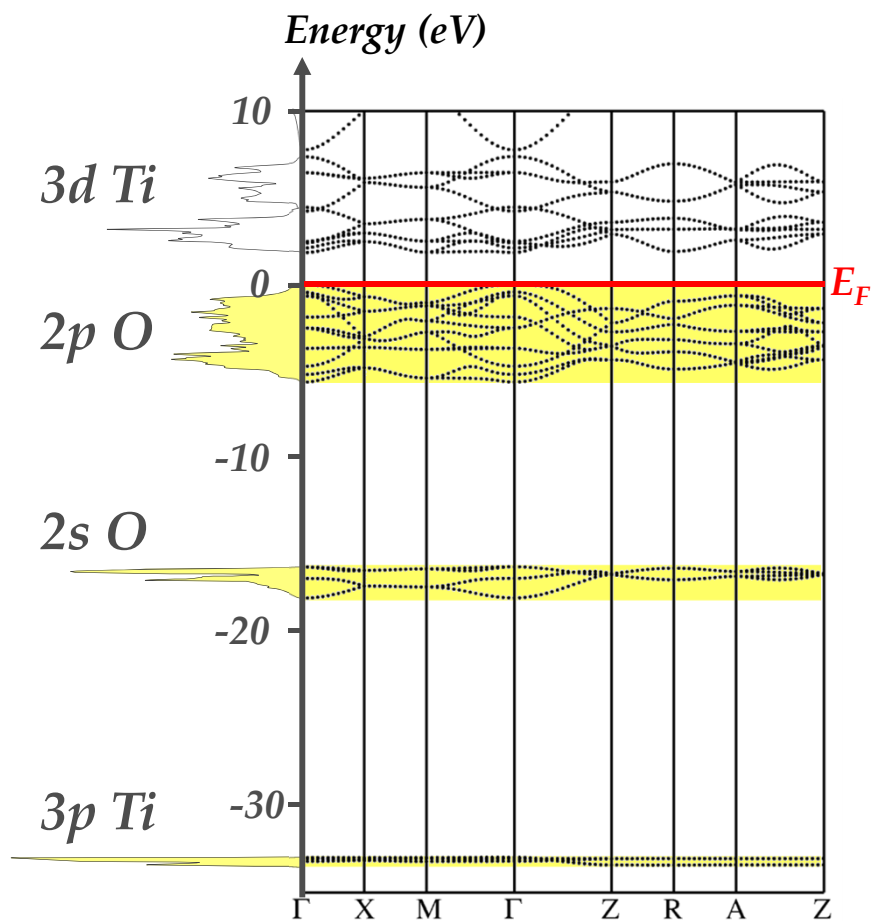



## 6 – ILLUSTRATIONS: $\text{TiO}_2$ series

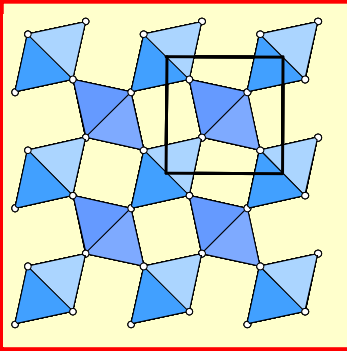

*Example of the rutile phase*

*Atomic structure*



*Electronic structure*



*Dielectric function*

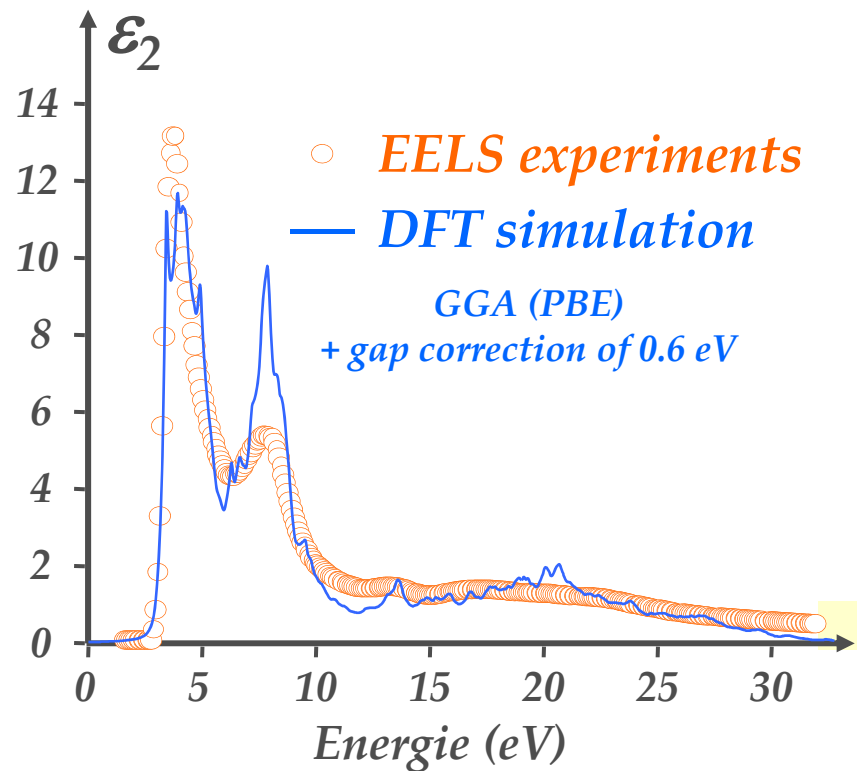
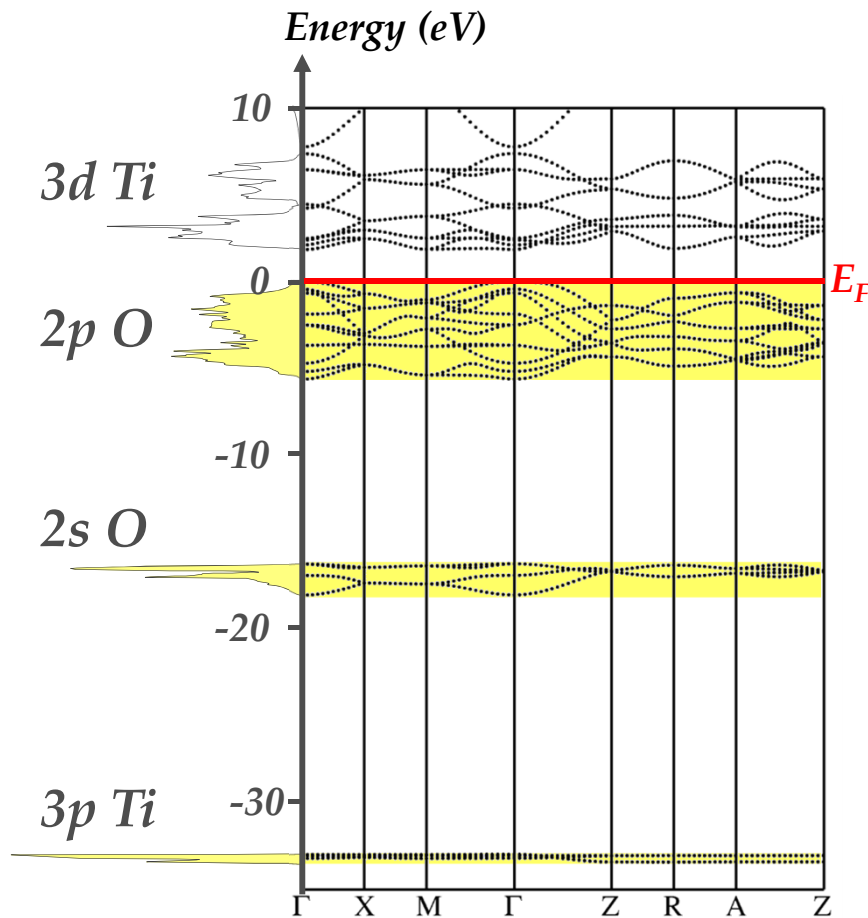

## 6 – OPTICS IN WIEN2k

- 0 normal SCF run  $\longrightarrow$  converged density
- 1 x `kgen`  $\longrightarrow$  dense `k-mesh` (check `convergence!`)
- 2 x `lapw1 -options`  $\longrightarrow$  eigenvectors on dense mesh and high  $E_{\max}$
- 3 x `lapw2 -fermi -options`  $\longrightarrow$  `case.weight`
  - metals: “TETRA 101.0” in `case.in2`
- 4 x `optic -options`  $\longrightarrow$  momentum matrix elements  
`case.symmat`:  $\langle ck | \hat{p}_j | vk \rangle \langle vk | \hat{p}_j | ck \rangle$
- 5 x `joint`  $\rightarrow$   $\text{Im } \epsilon_{ij}(\omega)$  , (`case.joint`) (JDOS\*`symmat`)
- 6 x `kram`  $\rightarrow$   $\text{Re } \epsilon_{ij}(\omega)$  , other optical funct. ,  
broadening, scissor operator
- 7 `opticplot`

## 6 – SOME ADDITIONAL DETAILS

### spin-polarized calculations

- 1 x joint -up && x joint -dn
- 2 addjoint-updn
- 3 x kram

### procedure for metals

- 1 x joint (mode=6)  $\longrightarrow$  plasma frequencies  $\omega_{p_{ij}}$
- 2 x joint (mode=4)  $\longrightarrow$  interband  $\text{Im } \epsilon$
- 3 x kram (intra=1, insert  $\omega_p$ )

Kramers-Kronig needs  $\text{Im } \epsilon$  in a large energy range

$$\text{Re } \epsilon_{ij} = \delta_{ij} + \frac{2}{\pi} \mathcal{P} \int_0^{\infty} d\Omega \frac{\Omega}{\Omega^2 - \omega^2} \text{Im } \epsilon_{ij}$$

## 6 – ILLUSTRATIONS: $\text{TiO}_2$ series

### TiO2-RUT.inop

2000 1 number of k-points, first k-point  
-5.0 5.0 Emin, Emax in Ry for matrix elements  
2 number of choices (columns in \*outmat)  
1 Re xx  
3 Re zz  
OFF write unsymmetrized matrix elements to file?

#### Choices:

1.....Re <x><x>  
2.....Re <y><y>  
3.....Re <z><z>  
4.....Re <x><y>  
5.....Re <x><z>  
6.....Re <y><z>  
7.....Im <x><y>  
8.....Im <x><z>

## 6 – ILLUSTRATIONS: TiO<sub>2</sub> series

### TiO2-RUT.injoint

1	261		LOWER AND UPPER BANDINDEX
0.0000	0.00100	10.0000	EMIN DE EMAX FOR ENERGYGRID IN ryd
	eV		output units eV / ryd / cm-1
4			SWITCH
2			NUMBER OF COLUMNS
0.1	0.1	0.3	BROADENING (FOR DRUDE MODEL - switch 6,7 -ONLY)

#### SWITCH:

0...JOINTDOS FOR EACH BAND COMBINATION  
1...JOINTDOS AS SUM OVER ALL BAND COMBINATIONS  
2...DOS FOR EACH BAND  
3...DOS AS SUM OVER ALL BANDS  
4...Im(EPSILON)  
5...Im(EPSILON) for each band combination  
6...INTRABAND contributions  
7...INTRABAND contributions including band analysis

### TiO2-RUT.inkram

0.1	<i>Gamma: broadening of interband spectrum</i>
0.6	<i>energy shift (scissors operator)</i>
0	<i>add intraband contributions? yes/no: 1/0</i>
12.60	<i>plasma frequencies (from joint, opt 6)</i>
0.20	<i>Gammas for Drude terms</i>

## 6 – ILLUSTRATIONS: $\text{TiO}_2$ series

### Files generated by:

- x **optic** →  $\text{TiO}_2\text{-RUT.symmat}$ 
  - $\text{TiO}_2\text{-RUT.mommat}$
  
- x **joint** →  $\text{TiO}_2\text{-RUT.joint}$
  
- x **kram** →  $\text{TiO}_2\text{-RUT.epsilon}$ 
  - $\text{TiO}_2\text{-RUT.sigmak}$
  - $\text{TiO}_2\text{-RUT.refraction}$
  - $\text{TiO}_2\text{-RUT.absorption}$
  - $\text{TiO}_2\text{-RUT.eloss}$

# 6 –ILLUSTRATIONS: MQ series ( $M = \text{Zn, Cd}$ & $Q = \text{O, S, Se, Te}$ )

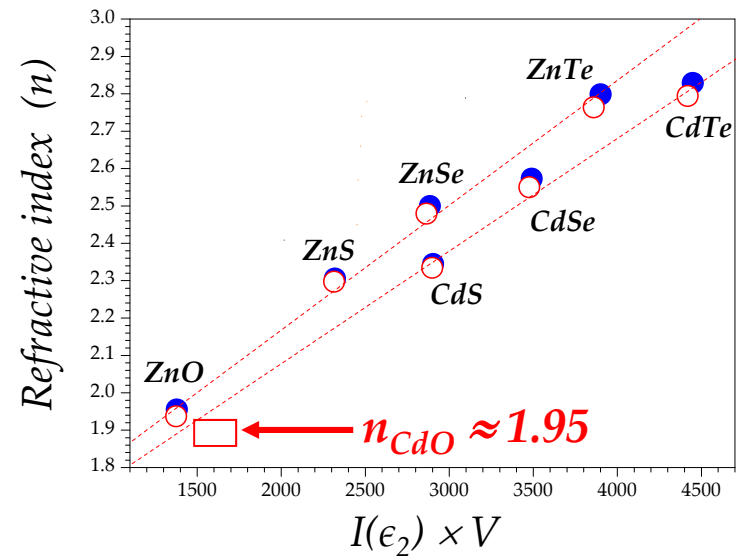
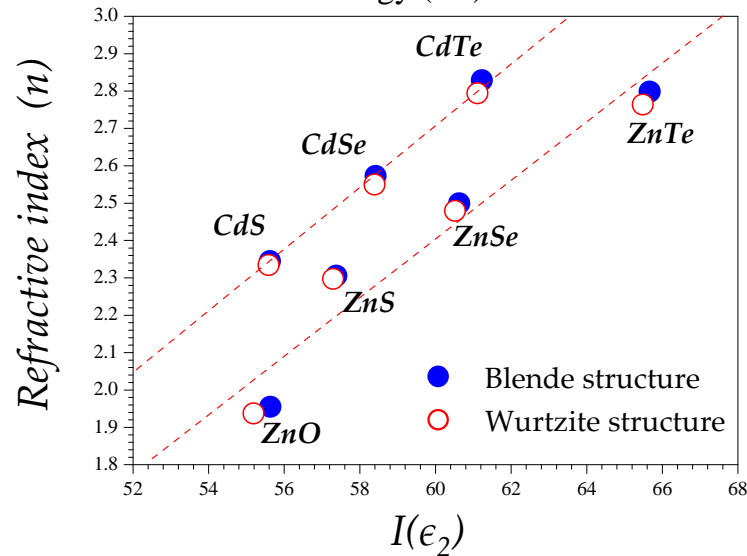
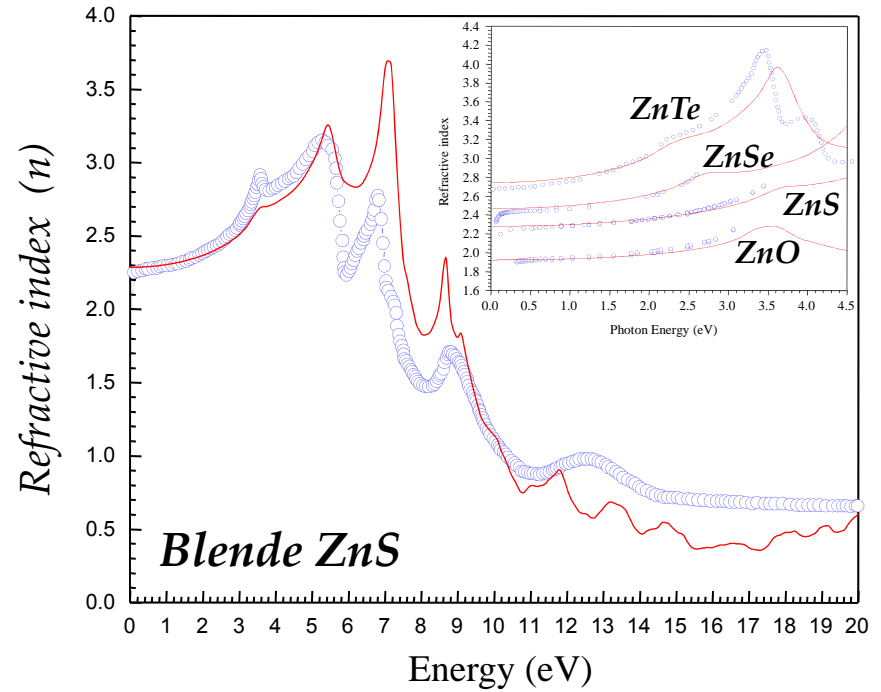
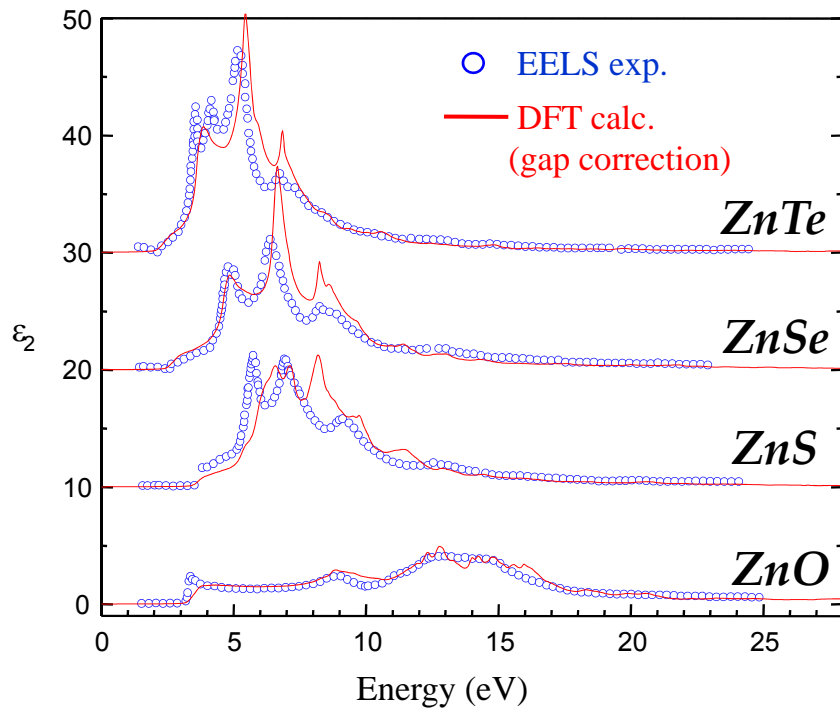

## 7 – Limitations:

*The band gap problem → Necessity to go beyond DFT*

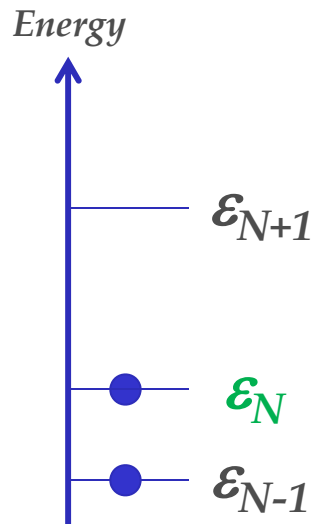

$$E_g = \varepsilon_{N+1}(N+1) - \varepsilon_N(N) = I - A$$

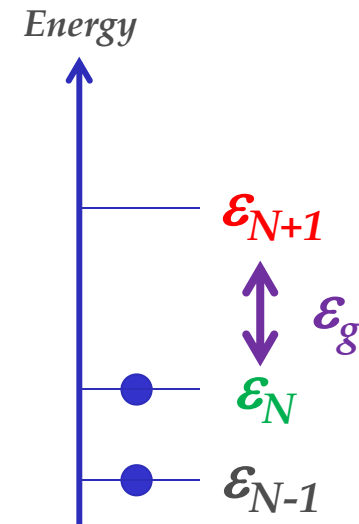
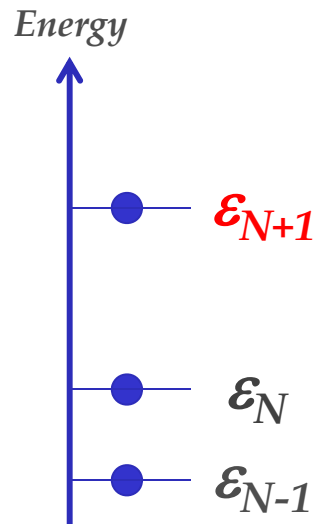

$$E_g = \varepsilon_{N+1}(N) - \varepsilon_N(N)$$

$$E_g = \underbrace{\varepsilon_{N+1}(2N) - \varepsilon_N(2N)}_{\text{DFT}} + \underbrace{\varepsilon_{N+1}(2N+1) - \varepsilon_{N+1}(2N)}_{\text{DFT}}$$

$$E_g = \varepsilon_g + \Delta_{xc} \quad \text{with } \Delta_{xc} \text{ Scissor Operator/mBJ/hybrid/GW...}$$

*Ionization energy:  $\varepsilon_N(N) = -I$*

*Electro-affinity:  $\varepsilon_{N+1}(N+1) = -A$*



## 5 – OPTICAL PROPERTIES SIMULATION IN WIEN2k

*Fundamental gap: electronic gap  $\neq$  optical gap*

**Deduced from the band structure**

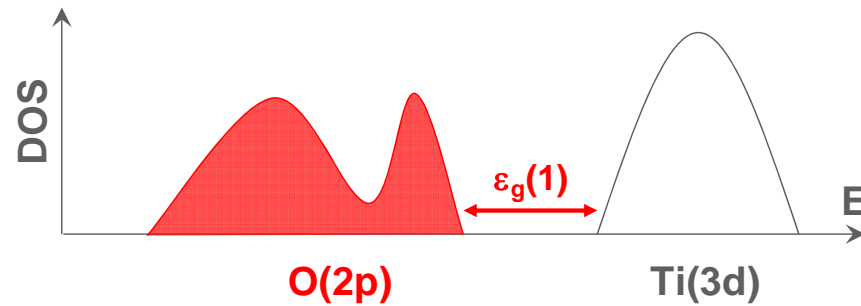

**Dipolar transitions**

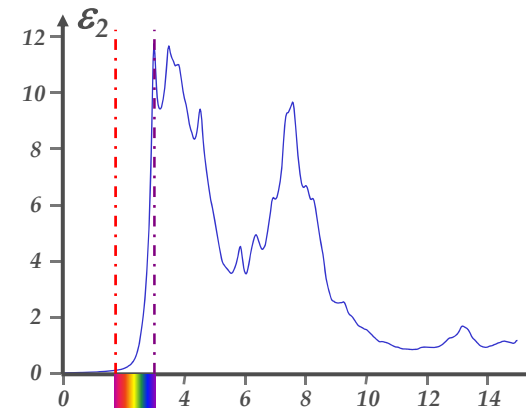

## 5 – OPTICAL PROPERTIES SIMULATION IN WIEN2k

*Fundamental gap: electronic gap  $\neq$  optical gap*

**Deduced from the band structure**

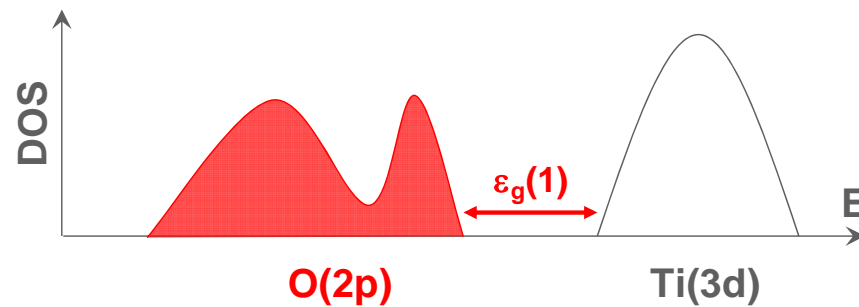

**Dipolar transitions**

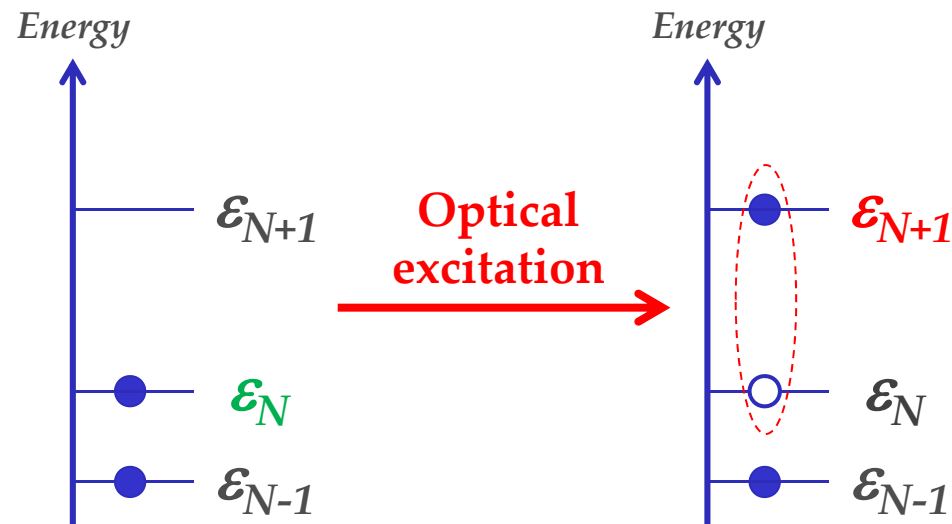
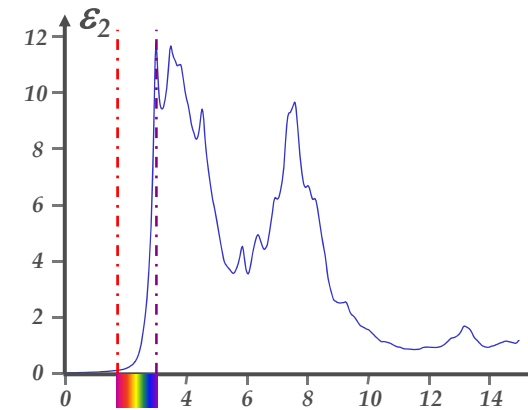

*If excitonic effects:  
we should go beyond  
(TDDFT / BSE)*

## *7 – Some limitations of DFT simulation of optical properties*

- **Kohn-Sham eigenstates interpreted as excited states**
- **Independent-particle approximation (no  $e^- - h^+$  interaction)**
  - Use of Bethe-Salpeter Equation (BSE) – Time-dependent DFT
- **LDA/GGA are not exact**
  - Use of hybrid DFT, effective potentials
  - Use of DFT+U, LDA+DMFT, GW...